

MEDICAL



COLLECTORS



ASSOCIATION

NEWSLETTER NO. 15
March 1989

Dear Colleagues:

Greetings to everyone for the first Newsletter of this year.

Most important among the items to be discussed is the announcement for the Fourth Annual Medical Collectors Association meeting which will be held in Cleveland, Ohio, July 27th through the 29th. If you have not already signed up for this meeting, please do so as soon as possible. It promises to be extremely exciting with the Dittrick Museum hosting a session and an opportunity to see Dr. Olgierd Lindan's collection on medical quackery, which is probably unique within the United States. Also enclosed with this issue you may have a notice that you have not yet paid your dues. If you have not paid your dues, this will be the last issue that you will receive. I appreciate receiving a note back from those of you who do not wish to renew their memberships, as well as those of you who do. Therefore, if you wish to remain a member please send in your dues for this year as soon as possible; if you do not wish to become a member for this year, please let me know.

Once again we have a reprint of an item from VIM AND VIGOR MAGAZINE, which was prepared by Dr. Robert E. Kravetz of Phoenix, Arizona, and also a reprint from PHARMACY IN HISTORY of the series "Historical Images of the Drug Market", by Mr. William H. Helfand. Thanks to both of you for your continuing support of the Association and contribution.

After a long hiatus of little or no interest, we have finally received not one but three interesting items for identification in the "Can you Identify This" column. Please review these items and if you have any comments to make to clarify their origins, send me a note and I will include it in the next Newsletter. We are indebted to Dr. Ulrich Danckers for submitting the hygrometer to the identification column, and to Dr. J. William Rosenthal for the interesting pair of hallmarked spectacles. We also have a contribution from Dr. Allen Kaufman who has submitted some type of scoop which he would like to have identified.

A former member of the group, Miss Wynona Crossgrove, was kind enough to send me some material from ARS CHIRURGICA by Salman. This interesting section which describes a variety of antique medical instruments, described in a volume dating from 1698, should be of interest to all of the collectors in the group.

The interest in stethoscopes among the membership and among collectors at large seems to be extraordinarily great. This certainly appears to be suggested by the geometric increase in the prices of these instruments over the past few years. I have also included in this letter a photocopy of a section of an article by Dr. Daniel S. Lamb from the 1910 "Washington Medical Annals".

Founder: M. Donald Blaufox, M.D., Ph.D.

I recently acquired a most interesting volume by Phillip S. Wales on Surgical Apparatus, Appliances, etc. and have photocopied the chapter on bloodletting for inclusion in the Newsletter. This is a subject of intense interest to most collectors and, therefore, I thought it would be worthwhile to include.

Once again Alex Peck has been kind enough to submit an interesting item for the Newsletter, in this instance some pages from a Civil War diary.

For those of you who have some interest in bottles, I'd like to bring to your attention the collection of Samuel J. Greer, which is currently being auctioned off by the Harmer Rooke Galleries, 3 East 57th Street, New York, N.Y. 10022. The collection has had two sessions but a third session remains with some magnificent bottles which probably could not easily be duplicated again. Dr. Greer's collection was truly one of the finest in the country. Perhaps of even greater interest than the acquisition of some of the bottles is, I think, the acquisition of the catalogue. Harmer Rooke is charging \$20 for this catalogue which is an incredibly complete listing of pontilled medicine bottles both clear and colored and includes estimates of the prices as well. At the conclusion of each session the company is sending out the realized bids so that the purchase of a single catalogue would provide any collector with an invaluable reference to the current value of more than one thousand important and rare pontilled medicine bottles.

While I was at a medical meeting last year, I encountered the revitalizer. This device is very reminiscent of many ancient items that the membership collects and I have included a photocopy of their claims and advertisement for the interested readership.

I also recently heard from the American Institute of the History of Pharmacy about the formation of a chapter in the New York/Philadelphia/Connecticut area, and the announcement is included as well. Also of some interest to those of you in this area is the exhibit at the New York Academy of Medicine. I recently had the opportunity to set up in the library a number of interesting examples which are part of the New York Academy of Medicine collection. The exhibit consists mostly of cased sets and is remarkable in both the rarity and quality of the devices. Those of you who live in the New York area, if you have an opportunity, might wish to look at this exhibit. I'd also appreciate any comments and hopefully I have not made any historical errors in the identification of the instruments.

Dr. Lloyd Zbar points out that the January 1989 issue of the JOURNAL OF THE ROYAL SOCIETY OF MEDICINE has some interesting material about instrument makers. I have not yet had a chance to obtain permission to copy this for the Association, but I hope to have a reprint of it available for the next issue.

Larry Adams has submitted a large amount of material to the Newsletter, including an extensive list of books which he is seeking out. Those of you who have books you wish to dispose of might consider contacting Larry. Also included in this Newsletter is a certificate from the McCleary Sanitarium with a brief description of Larry's wants in that area, and a number of very interesting and unusual patents which he supplied to me.

The Science Heritage Limited Foundation has sent me further material about the availability of their limited edition on the History of the Microscope. People

interested in getting more information about this should contact the organization directly at Science Heritage Limited, P.O. Box 46372, Chicago, Illinois 60646.

The volume of material which has been crossing my desk has been drifting in at a somewhat slower rate than last year. Because of this, I have decided to put out a very expanded Newsletter this spring. You will note that there is virtually double the amount of material in this Newsletter compared to the usual size. I will plan to put out a second Newsletter in the fall which will also be larger than usual. If material starts coming in at a more rapid rate, then I will prepare a Newsletter in the summer but as it stands now, the members should expect to receive two enlarged Newsletters this year instead of three smaller ones.

Once again I remind you of the Scientific Instrument Fair which is scheduled for Sunday, April 23, 1989.

I look forward to seeing as many of you as possible at the meeting in July. Please continue to send me as much information as possible so that we can maintain a quality communication in the form of the Newsletter.

Sincerely,

M. Donald Blaufox, M.D., Ph.D.

MDB:IR

A LOOK BACK

FASCINATING ARTIFACTS FROM THE HISTORY OF MEDICINE

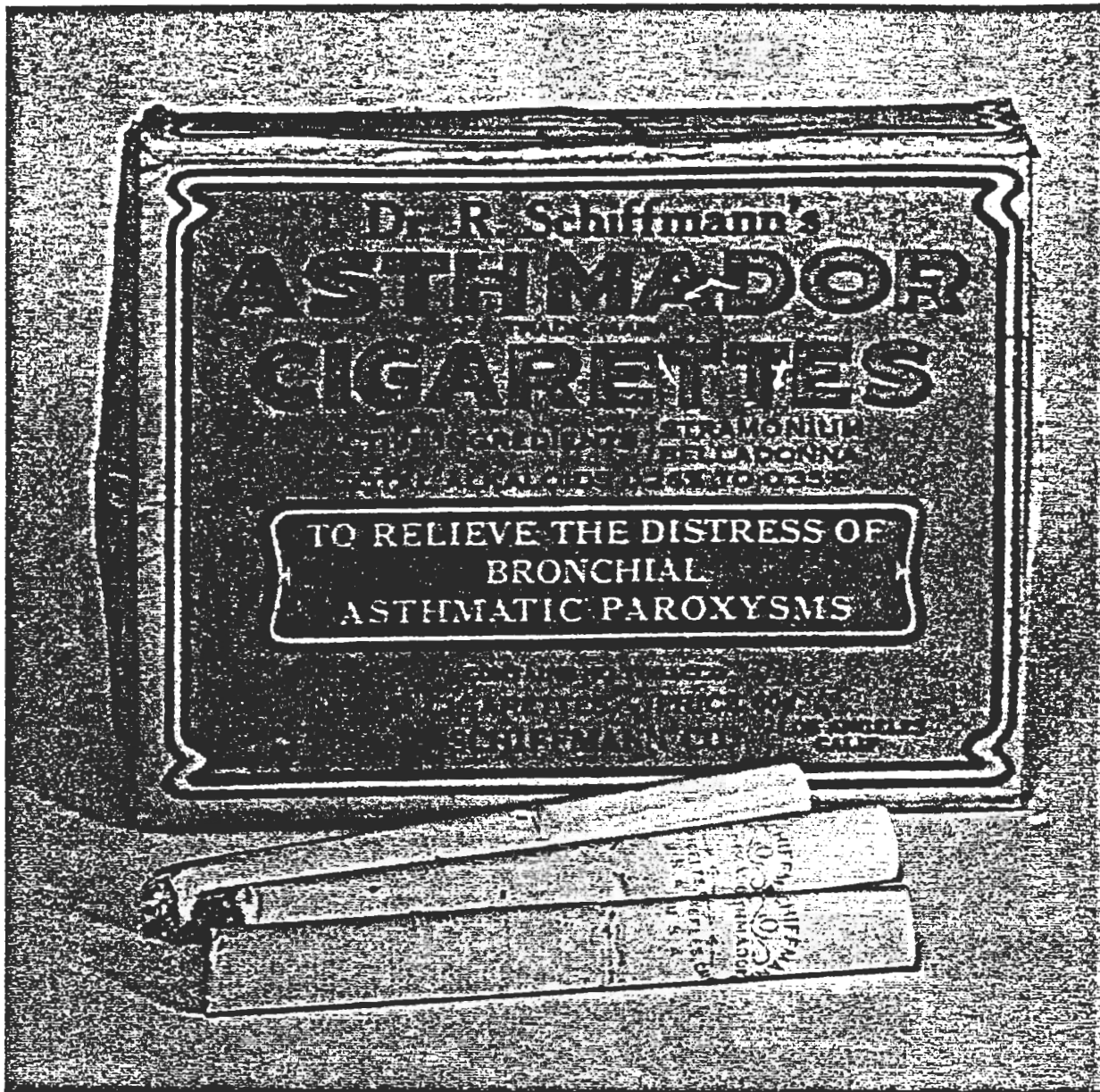

MEMORABILIA COURTESY OF ROBERT E. KRANITZ, M.D., CURATOR, MEDICAL MUSEUM, PHOENIX BAPTIST HOSPITAL. PHOTOGRAPH BY STEVE LOCKRIS.

Cigarettes made from the leaves of deadly nightshade (belladonna) and jimson weed (stramonium) plants have been used for centuries to relieve asthma. Both plants contain atropine and hyoscyamine, theoretically effective in relaxing the respiratory passages and reducing secretions which plug the airways in asthma.

Even the eminent physician Sir William Osler recommended asthma cigarettes for

the relief of his patients. Although an occasional patient did benefit from this remedy, the results were usually far from brilliant.

The smoke was irritating and often aggravated the asthma attack, making many patients worse. The "Asthmador Cigarettes" pictured here present an interesting paradox considering medical science's 1987 viewpoint on smoking. 

Copyright © 1988 Vim & Vigor, Inc.
Reprinted with permission.

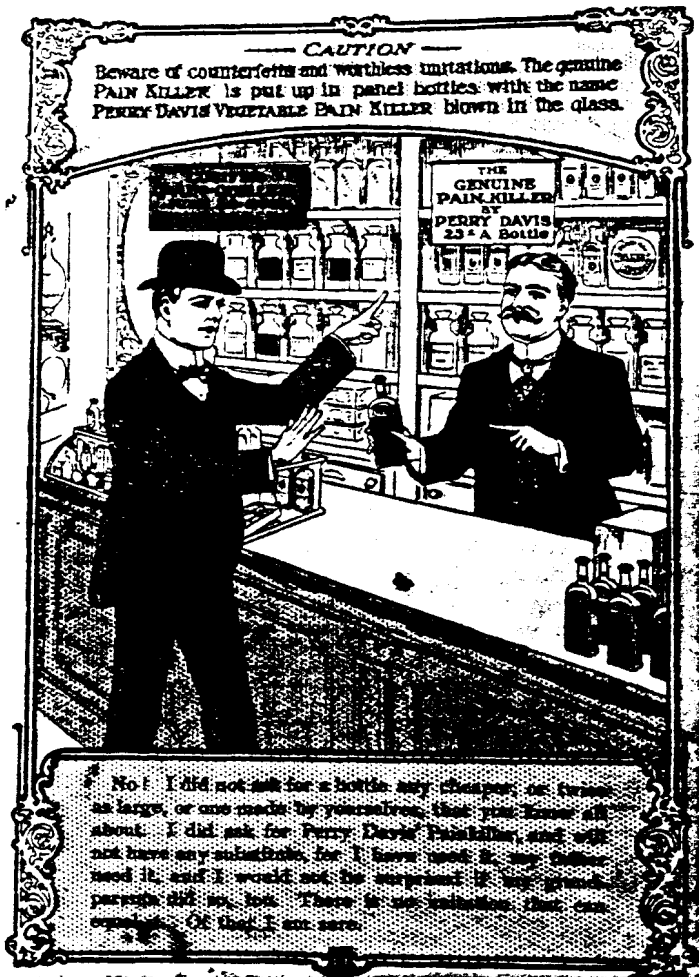

Historical Images of the Drug Market—XIV

by William H. Helfand

PHARMACISTS' prescription volume often has been affected by physician dispensing, and during periods of economic difficulty, the effect has been severe. The reverse side of the coin has been counterprescribing, which has been equally decried by physicians. This activity has also had a distinct impact on proprietary medicine manufacturers, who have fought back by repeatedly advising their clients to "accept no substitutes." "beware of counterfeits," or to observe that there are "none genuine without the signature." The proprietors of Perry Davis' Pain Killer showed just how one should respond to the pharmacist who would offer

a substitute in this illustration on the back cover of a pamphlet published around 1900 advertising the many uses of its product. The anguished customer's response, in lines below the illustration was quite certain. "No! I did not ask for a bottle any cheaper, or twice as large, or one made by yourselves, that you know all about. I did ask for Perry Davis' Painkiller, and will not have any substitute, for I have used it, my father used it, and I would not be surprised if my grandparents did so, too. There is no imitation that can equal it. Of that I am sure." (*Size of illustration, 3% × 3%*).

CAN YOU IDENTIFY THIS

Material: Glass, but not for silver or silver

Maker: Unknown

Presumed Use: Unknown

Date: Unknown

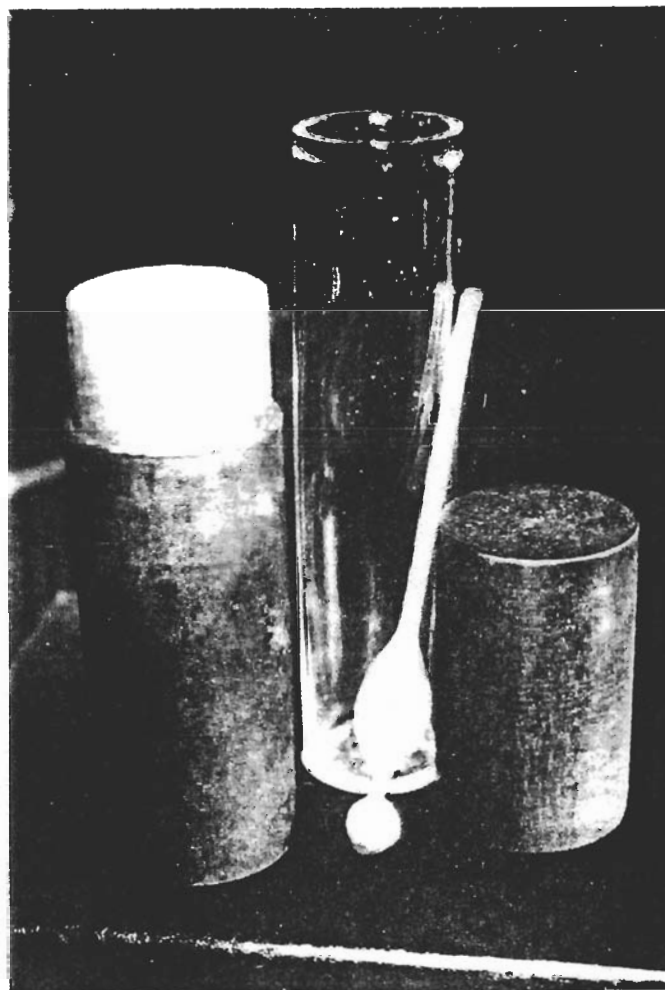

I Think This is:

From:

Please Return To M.Donald Biaufox, M.D.,PhD.

CAN YOU IDENTIFY THIS

Material: Wood and metal

Maker: Unknown

Presumed Use: Unknown

Date: Unknown



EBONY
HANDLE

ACTUAL
SIZE



I Think This is:

From:

Please Return To M.Donald Blaufox, M.D.,PhD.

C. 1780?

CAN YOU IDENTIFY THIS

Material: Brass with square frosted plano lens (indicated by squares on foto)

Maker: Unknown

Presumed Use: Unknown

Date: Unknown - see hallmark

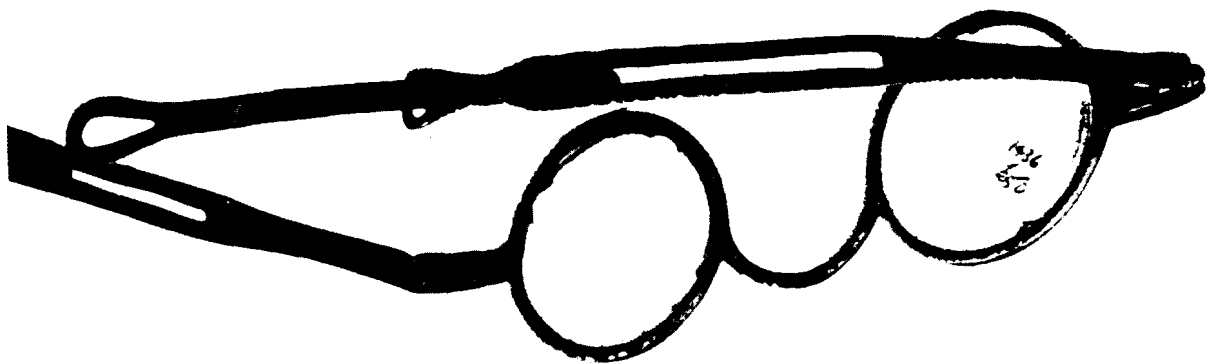
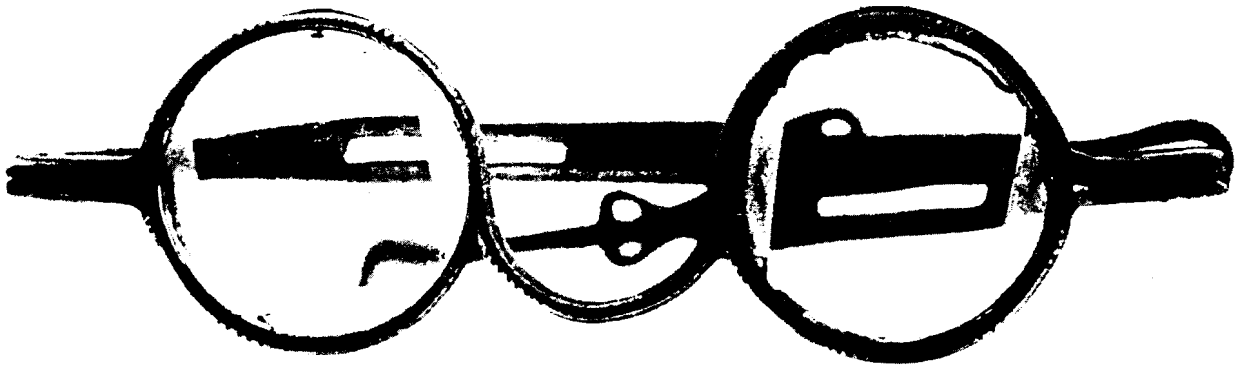

I Think This is:

From:

Please Return To M.Donald Blaufox, M.D.,PhD.

The McCLEARY SANITARIUM

ESTABLISHED OVER A QUARTER CENTURY

Specializing in
RECTAL AND
COLONIC DISEASES

A.S. McCLEARY M.D.
FOUNDER
T.G. McCLEARY M.D.
CHIEF OF STAFF

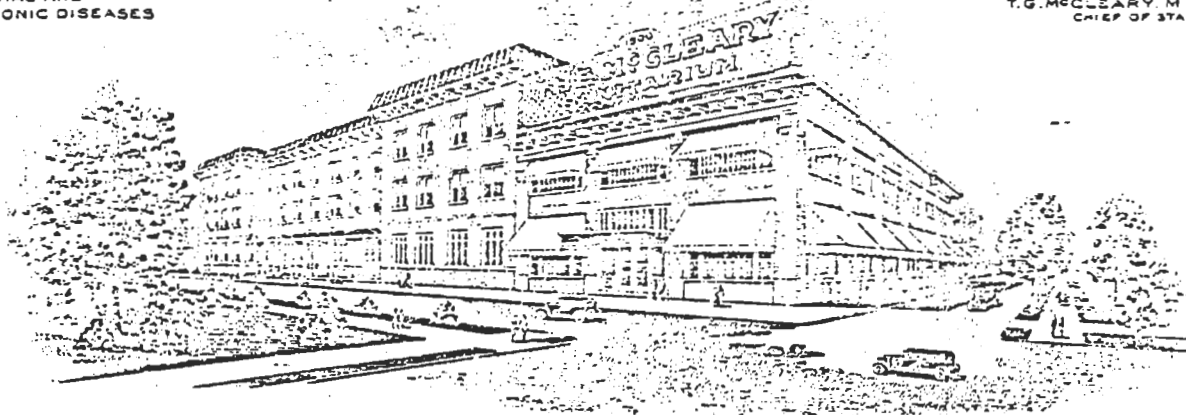

EXCELSIOR SPRINGS, MO.

Lifetime Certificate

This Certifies that

Mrs. A. A. Clatt, Colo Iowa

has been a patient of The McCleary Sanitarium for the treatment of rectal trouble.

Should the patient named herein ever again be troubled with any rectal disorder, The McCleary Sanitarium agrees that upon the completion of all agreements made by the above mentioned patient and that upon the return of said patient to this Institution, all Rectal treatments will be furnished free of charge.

This agreement to be binding on Dr. McCleary or in case of his death or disability on his successors in this Institution.

Signed this 17th day of June 1935

Accepted:

T. G. McCleary M.D.

Mrs. A. A. Clatt

Patient

G. F. P. O.

No. 28589



The Value of ESCHAROTICS

*Medicines which will Destroy any Living
or Fungus Growth in the Treatment of CANCER,
LUPUS, SARCOMA and other forms of Malignancy*

PERRY NICHOLS, B.S., M.D. & Co-workers



THE DR. NICHOLS SANATORIUM

Savannah, Missouri

1949

(No Model.)

M. McCORMICK.
SURGICAL APPLIANCE.

No. 587,994.

Patented Aug. 10, 1897.

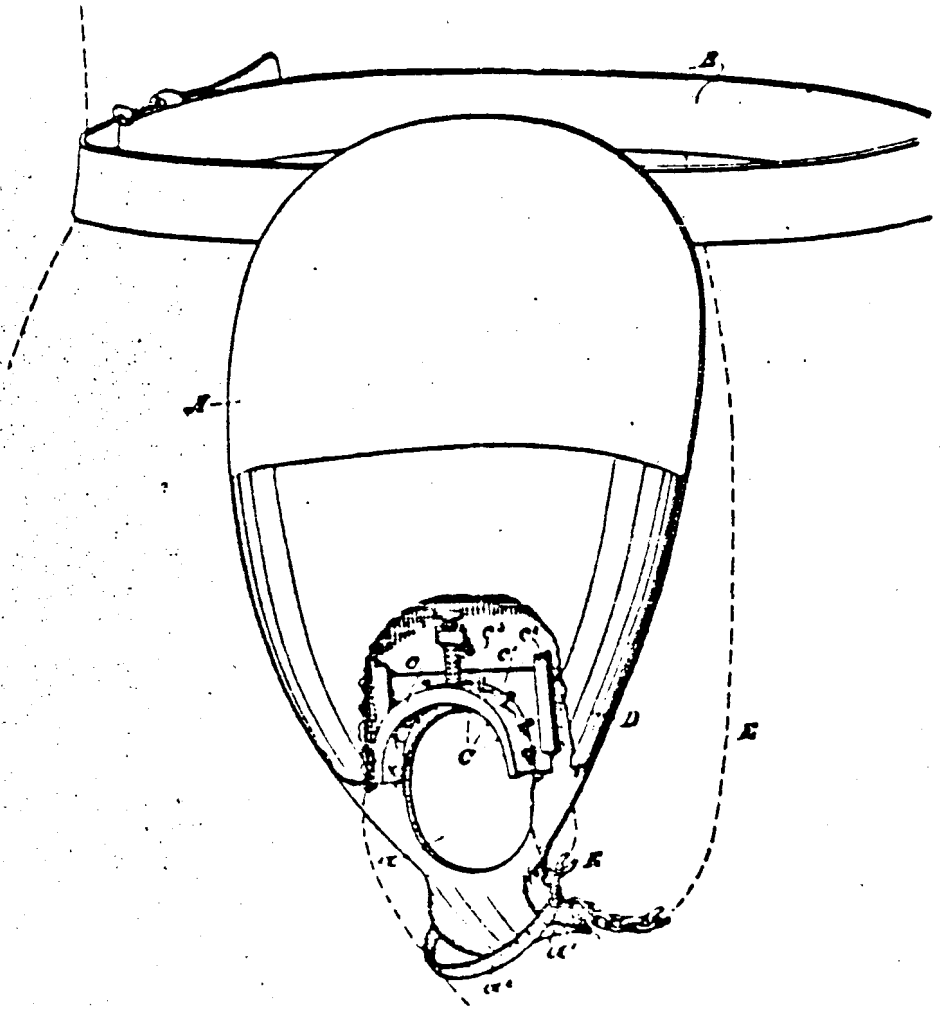

Witnesses,
Johnston
J. F. Elschack

Inventor,
Michael McCormick
By Dewey & Co.
Attys

UNITED STATES PATENT OFFICE.

MICHAEL McCORMICK, OF SAN FRANCISCO, CALIFORNIA.

SURGICAL APPLIANCE.

SPECIFICATION forming part of Letters Patent No. 587,904, dated August 10, 1897.

Application filed November 27, 1896. Serial No. 812,686. (No model.)

To all whom it may concern:

Be it known that I, MICHAEL McCORMICK, of the city and county of San Francisco, State of California, have invented an improvement in Surgical Appliances; and I hereby declare the following to be a full, clear, and exact description of the same.

My invention relates to the general class of surgical appliances; and it consists in the novel construction and arrangement of the device or appliance which I shall hereinafter fully describe.

The objects of my invention, generally stated, are three, to wit: first, to prevent involuntary nocturnal seminal emissions; second, to control waking thoughts, and, third, to prevent self-abuse.

Referring to the accompanying drawing, the figure is a view of my device.

A is a plate, of any suitable material, conforming sufficiently to the shape of the abdomen to enable it to be worn thereon with convenience and to be secured thereto by any suitable fastenings—*aa*, for example, by a belt B about the waist. The lower extremity of this plate is provided with an aperture *a*, below which is a flanged lip *a'*, provided with a top fastening, such as an elastic or yielding strap *a''* or other device adapted to hold the member down in said lip, as I shall hereinafter explain.

Upon the lower portion of the plate and just above the aperture *a* is a pricking-point, or, as here shown, a series C of such points. These, though they may be fixed or stationary, are preferably adjustable by being formed on the ends of screw-stems, which are best carried by a semicircular piece *c*, which is itself carried in a plate *c'*, adapted to slide in guides *c''* and to be adjusted up or down by means of an adjusting-screw *c'''*. These parts are best protected by a cover-plate or shield D, secured to plate A.

The device is adjusted to the person by fitting plate A over the abdomen and securing it by belt B. The organ is passed through the aperture *a*, which fits close up around the base, and this member is then drawn down and rests in the lip *a'* and is secured lightly therein by the band or strip *a''*. The pricking-points are adjusted so as to lie in such

proximity above, though clear of, the organ, as may be found best.

The member, being drawn and held down in lip *a'*, will as long as there is no excitement not be in contact with the pricking-points and will be positively held clear thereof. Now when from any cause expansion in this organ begins it will come in contact with the pricking-points, and the necessary pain or warning sensation will result.

If the person be asleep or otherwise inattentive, he will be awakened or recalled to his senses in time to prevent further expansion. If he be asleep, an involuntary emission will be prevented by his awakening. If he be inattentive or if through forgetfulness or any other cause his thoughts should be running in lascivious channels, these will be diverted. Voluntary self-abuse will be checked, presuming the wearer be desirous of benefit, as he will not take the trouble to relieve himself of the appliance, and he cannot continue his practice without removing it.

If the wearer be irresponsible from any cause, the appliance can be permanently secured to him, as by a protected line E, extending from the lip *a'* to the back of belt B, and the fastening-strip *a''* may be of some permanent character, like sticking-plaster, which will prevent the removal of the extremity of the member from lip *a'*.

Having thus described my invention, what I claim as new, and desire to secure by Letters Patent, is—

1. A surgical appliance consisting of a suitable frame or plate adapted to be fitted and secured to the body, said frame having an aperture through which the organ or member is to be passed, and having a lip extending downwardly from said aperture, a plate mounted in guides on the frame and having means by which its position may be adjusted in a vertical plane, and pricking-points carried by the slidable plate and each capable of independent adjustment thereon.

2. A surgical appliance consisting of a frame or plate having an aperture through which the organ or member is to be passed, and vertical guides, said frame having a downwardly-extending flanged lip below the aperture, a strap or band secured to the lip and adapted

to hold the organ or member, a plate slidably fitted within said guides having a screw by which its position on the frame is adjusted, and pricking-points carried by the slidable plate and each capable of independent adjustment, said points adapted to sensibly contact with the organ or member as the latter expands.

3. A surgical appliance consisting of a suitable plate or frame adapted to be fitted and secured to the body and having an aperture in its lower portion through which the proper member is to be passed, a vertically-adjustable series of pricking-points having threaded stems independently mounted on said plate or frame above its aperture, and with which said mem-

ber will come in contact as it expands, and means on the plate or frame below for holding said member down normally out of contact with said series of pricking-points. 20

4. A surgical appliance consisting of the plate having the aperture and the lip with its fastening below said aperture, the adjustable series of pricking-points above said aperture, and the shield-plate protecting said 25 points.

In witness whereof I have hereunto set my hand.

MICHAEL McCORMICK.

Witnesses:

S. H. NOURSE,

H. F. ASCHECK.

1,033,788.

Patented July 30, 1912.

Fig. 1.

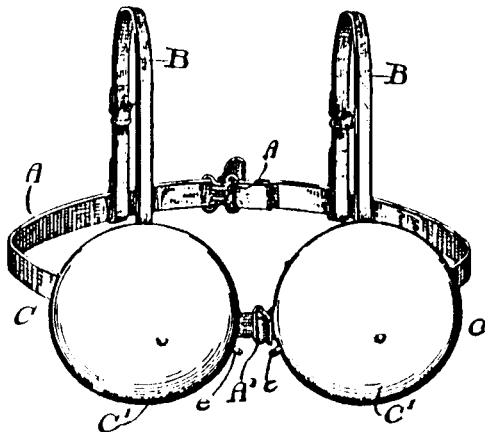

Fig. 2.

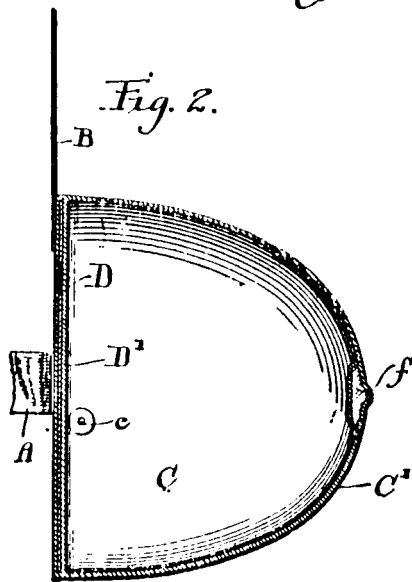
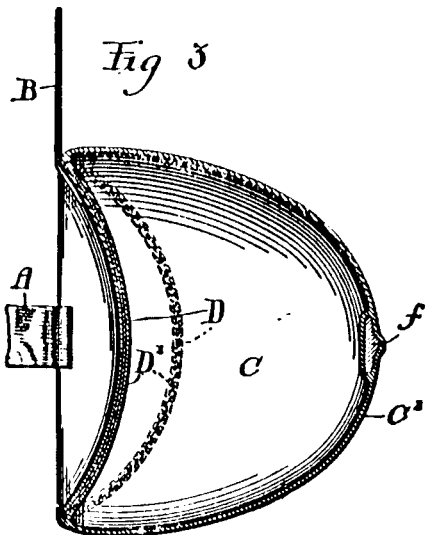

Fig. 3.



Mobile Bust-Form

UNITED STATES PATENT OFFICE

BUST-FORM

1,088,788

Specification of Letters Patent Patented July 30, 1912
Application filed August 6, 1908. Serial No. 447,194

. . . The invention relates to bust forms and designs to provide an improved device, designed to supply any natural deficiency of form and to support the breasts, which will effectively give the appearance of the natural bust, and which may be readily fitted to different breasts and worn with comfort. . . .

The invention further designs to construct the bust-forms so that when worn, they will not have the appearance of lifeless members, but will vibrate responsively to movements of the wearer. . . .

In use, when pneumatic pads are inflated and covered by garments, the bosom is sometimes rather lifeless in appearance, due to the inflated pads which do not readily or freely respond to the movements of the wearer's bosom. To overcome this appearance, a weight *f* is molded into the front of the casing *C*, and under the influence of the body is suspended at the front of the pad and sets the front in motion so that it will vibrate freely in response to any movement of the body of the wearer. . . .

949,414.

Patented Feb. 15, 1910.

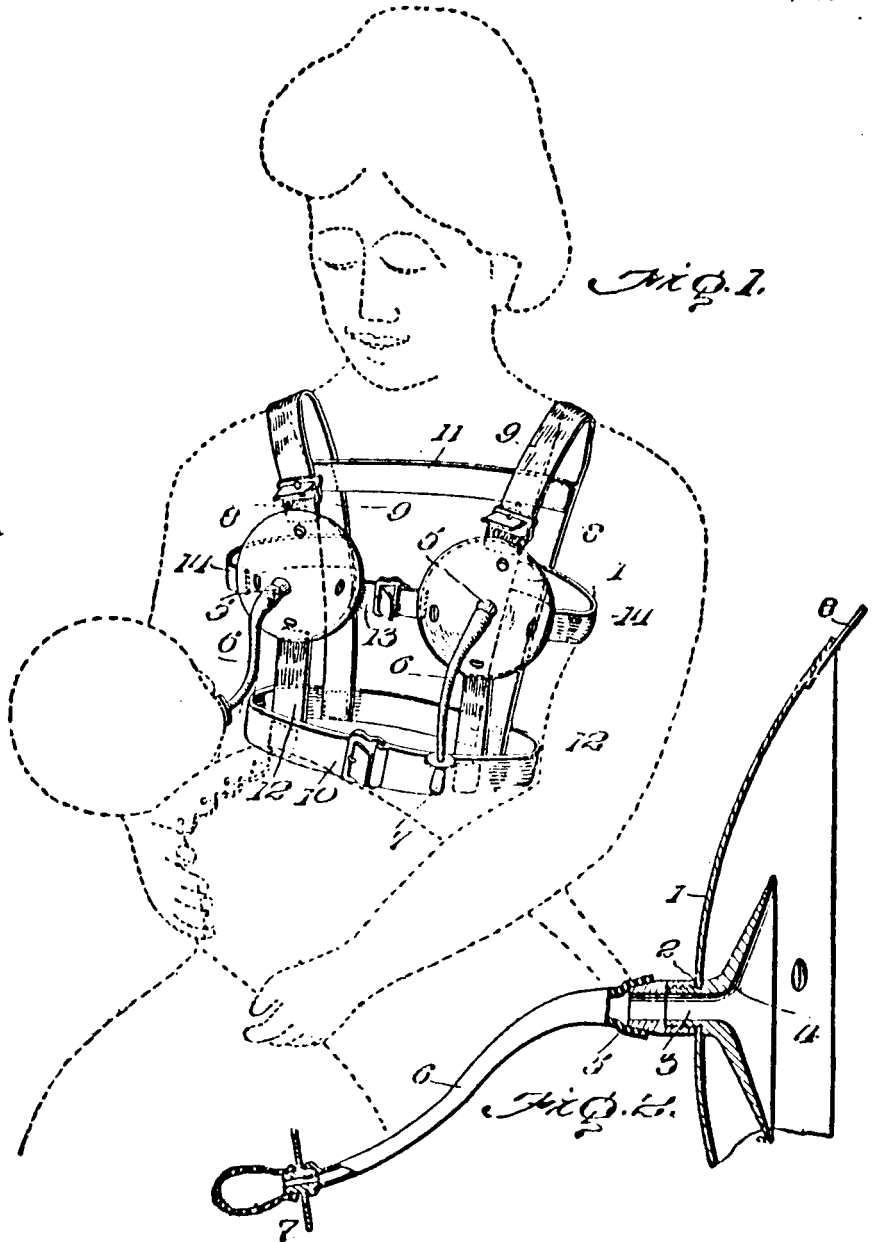

Device for Modest Mothers

UNITED STATES PATENT OFFICE NURSING ATTACHMENT

949,414

Specification of Letters Patent Patented Feb. 15, 1910
Application filed September 7, 1909. Serial No. 516,836

. . . The primary object of this invention is an improved construction of device for use by mothers with nursing infants, and designed particularly to avoid unpleasant and embarrassing situations in which mothers are sometimes placed in public places by the necessary exposure of the breast in suckling the child.

With this and other objects in view, as will more fully appear as the description proceeds, the invention consists essentially in a nursing attachment designed to be worn over the breasts and arranged for the detachable connection thereto of the nipple on a tube of any desired length, the nipple or nipples, according to whether there be one or two employed, being worn inside of the shirtwaist or other outer garment and it being only necessary when the child is to be nursed, to slip the nipple out of the waist, thereby avoiding the necessity of exposing the person. . . .

In the practical use of the device, the shields 1 are adjusted over the breasts with the cups 4 directly over the nipples and the cap or caps 5 are then attached, the nursing nipples 7 and all other parts being hidden beneath the wearer's waist. Whenever the child requires nursing it is only necessary to slide one of the nursing nipples 7 out from the waist and the child can obtain its proper nourishment without the exposure of the mother's person and the consequent embarrassment which is thus often occasioned. . . .

(No Model.)

DEVICE FOR PRODUCING DIMPLES.

No. 560,351.

Patented May 19, 1896.

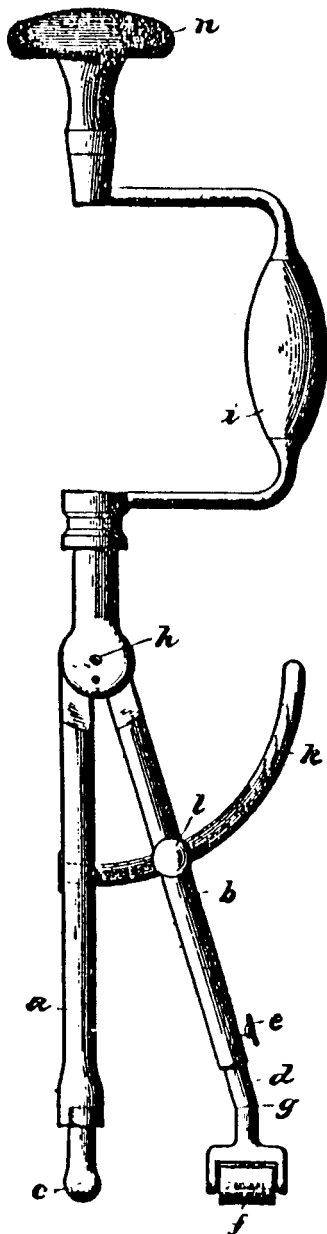

Dimple Tool

UNITED STATES PATENT OFFICE DEVICE FOR PRODUCING DIMPLES

Specification forming part of Letters Patent No. 560,851, dated May 19, 1896
Application filed May 25, 1895. Serial No. 550,658. (No model)

. . . The present invention consists of a device which serves either to produce dimples on the human body or to nurture and maintain dimples already existing.

In order to make the body susceptible to the production of artistic dimples, it is necessary, as has been proved by numerous experiments, that the cellular tissues surrounding the spot where the dimple is to be produced should be made susceptible to its production by means of massage. This condition is fulfilled by the present process as well as by the apparatus by which the process is worked, and which is represented in an enlarged form in the accompanying drawing. . . .

When it is desired to use the device for the production of dimples, the knob or pearl *c* of the arm *a* must be set on the selected spot on the body, the extension *d*, together with the cylinder *f*, put in position, then while holding the knob *n* with one hand the brace *i* must be made to revolve on the axis *x*. The cylinder *f* serves to mass and make the skin surrounding the spot where the dimple is to be produced malleable. . . .

Removing Tape Worms.

N^o 11,942.

Patented Nov. 14, 1854.

Fig. 1.

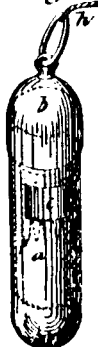

Fig. 2.



Trap for Tapeworms

UNITED STATES PATENT OFFICE TAPEWORM-TRAP

Specification of Letters Patent No. 11,942, dated November 14, 1854

. . . The object of my invention is to effect the removal of worms from the system, without employing medicines, and thereby causing much injury.

My invention consists in a trap which is baited, attached to a string, and swallowed by the patient after a fast of suitable duration to make the worm hungry. The worm seizes the bait, and its head is caught in the trap, which is then withdrawn from the patient's stomach by the string which has been left hanging from the mouth, dragging after it the whole length of the worm. . . .

The trap is baited by taking off the cover *b*, of the exterior box, and filling the interior box with the bait which may consist of any nutritious substance. The interior box *d*, is then pushed down until the stud *f*, catches between the teeth of the opening *e*, and holds it with the openings, *e*, and *c*, opposite each other, the points of the teeth being then below the lower edge of the opening *e*. The trap, having the cord *h*, attached to a ring *i*, on the lid is then swallowed. The worm, in inserting its head at the opening *e*, and eating the bait, will so far disturb the inner box as to work it free of the stud *f*, when the box will be forced upward by the spring *g*, and the worm caught behind the head, between the serrated lower edge of the opening in the interior box, and the upper edge of the opening in the exterior box. The trap and the worm may then be drawn from the stomach, by the cord *h*. . . .

ELECTRIC EXTRACTION OF POISONS.

(Application filed Oct. 5, 1896.)

(No Model.)



Electrotherapeutic Device

UNITED STATES PATENT OFFICE

ELECTRIC EXTRACTION OF POISONS

Specification forming part of Letters Patent No. 606,887, dated July 5, 1898
Application filed October 5, 1896. Serial No. 607,955. (No model)

. . . Be it known that I . . . have invented certain new and useful Improvements in the Electrical Extraction of Poisons from the Human Body; and I hereby declare that the accompanying is a full, clear, and exact description of the same, reference being had to the accompanying drawing, in which the figure is a view in perspective of a male subject or patient seated in a chair, the electric battery, and the conducting-wires leading from the electric battery to the positive and negative plates, which in the illustration are shown applied to the back of the neck of the patient and at the same time to the bare feet of the patient or person receiving treatment. . . .

For vegetable poisons I employ a vegetable receiver instead of a mineral or copper one, and for animal poisons I use an animal receiver, such as raw meat, the device being capable of use with the mineral, vegetable, or animal receivers without further change than to equip it with the kind of receiver applicable to the kind of poison desired to be extracted or removed from the human system. . . .

The application of the different receivers is made to the negative electrode, and the positive electrode is applied to any suitable part of the body. When the current is turned on, it will run down from the neck or other suitable place through the patient's body and will pull or draw out the poison at the negative pole and deposit it on the copper plate. From six to eight treatments of a half an hour each in duration will generally extract all of the poison of whatever kind it may be, and the copper plate will show as bright and clear as it was at first. The copper plate or other receiver may be applied to any part of the human body where poison may be found. . . .

BICYCLE AND MOTOR CYCLE SEAT

Filed Feb. 16, 1924

2 Sheets-Sheet 1

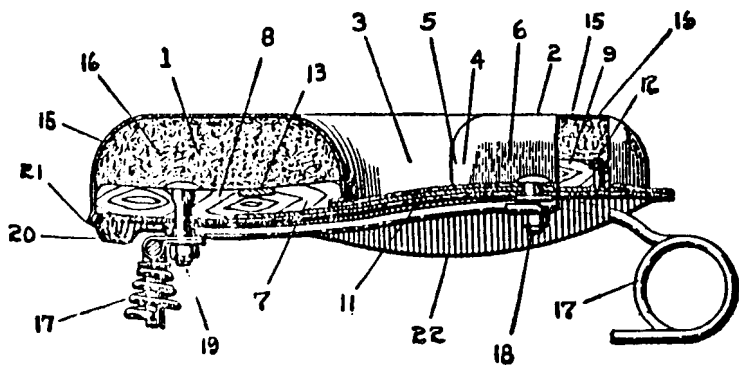
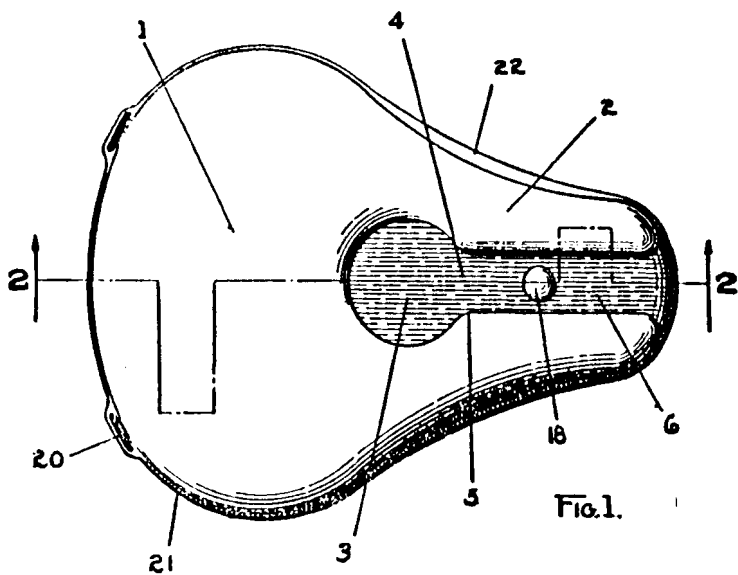

Bicycle Saddle for the Use of Either Sex

UNITED STATES PATENT OFFICE BICYCLE AND MOTOR-CYCLE SEAT

Patented May 19, 1925

1,588,542

Application filed February 16, 1924. Serial No. 698,827

. . . It is a primary object of my invention to provide a bicycle or motorcycle saddle having a suitable cavity properly located to allow comfortable clearance for the private organs of the male rider, said saddle having also a channel adapted to allow clearance for the female rider's private organs, to prevent pressure at the opening of said organs due to the weight of the rider, and tending also to keep said organs in a naturally closed state, the sides of said channel being substantially parallel and bell-mouthed. . . .

Referring to Fig. 1, a somewhat circular cavity 8 is formed on a medial line of the apparatus as a whole, at the junctions of said extension with said larger seating portion. Said cavity is of suitable size, shape and location to comfortably receive the private organs of a male rider and more particularly the testicle region of such rider. Said opening is of bell-mouthed formation, the bell-mouth character thereof being formed on the upper portion of said opening. Such bell-mouthed formation is particularly useful to the comfort of the male rider both during the riding act and also during the mounting or dismounting acts, said organs being slidably lodgeable or dislodgeable in relation to said opening when same is thus covered or uncovered by angular movement as compared to what may be called a vertical straight-away movement. . . .

SIPHON SPOUT.

(Application filed Nov. 10, 1899.)

(No Model.)

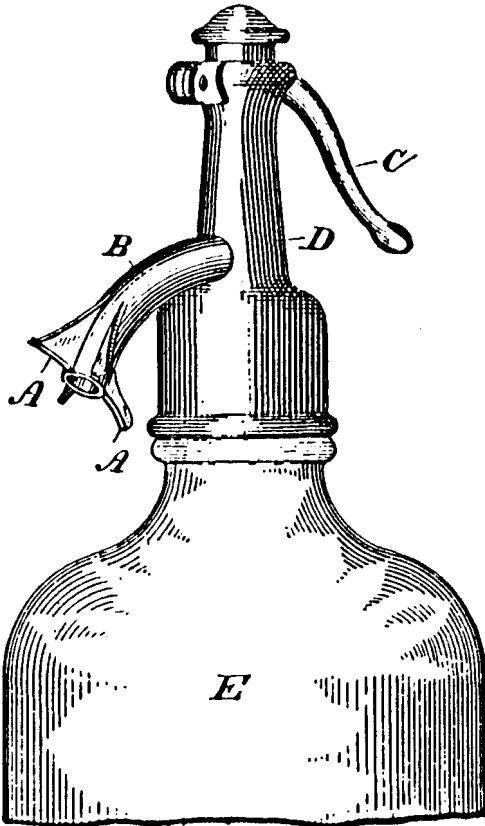

Hygienic Siphon

UNITED STATES PATENT OFFICE

SIPHON-SPOUT

Specification forming part of Letters Patent No. 641,201, dated January 9, 1900
Application filed November 10, 1899. Serial No. 786,565. (No model)

. . . My invention relates to projections on the mouth of the spout or nozzle of siphons; and the object of my improvement is to prevent the use of the siphon as a syringe by inserting it in or applying it to certain parts of the human body. I attain this object by the mechanism illustrated in the accompanying drawing, in which the diagram is a side view of the siphon. . . .

In using the siphon before my invention nothing prevented the insertion of the siphon-mouth in any opening of the body to be used as a syringe, thereby contaminating it with germs of disease. With my improvement in using the siphon as a siphon the projections *a* in no way interfere; but if it is attempted to misuse the siphon—*e. g.*, as a syringe—the projections *a* prevent an insertion in or application to any part of the body. . . .

METHOD OF PRESERVING THE DEAD.

APPLICATION FILED OCT. 13, 1903.

NO MODEL.

Fig. 1.

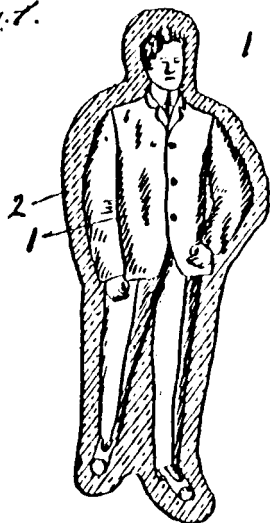

Fig. 2.

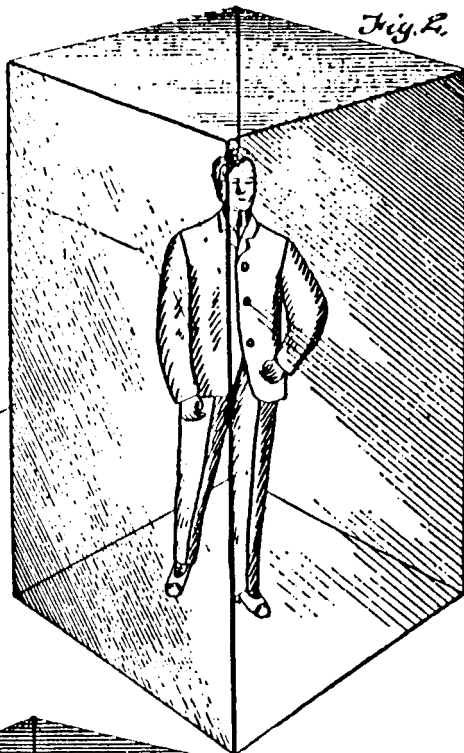
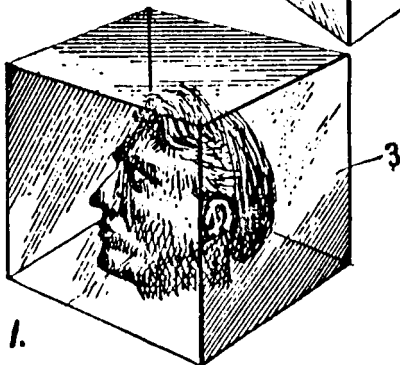

Fig. 3.



Water-Glass Sarcophagi

UNITED STATES PATENT OFFICE METHOD OF PRESERVING THE DEAD

No. 748,284

Patented December 29, 1903

Specification forming part of Letters Patent No. 748,284, dated December 29, 1903

Application filed October 18, 1903. Serial No. 176,922. (No specimens)

. . . This invention relates to certain new and useful improvements in methods of preserving the dead; and it has for its object the provision of a means whereby a corpse may be hermetically incased within a block of transparent glass, whereby being effectually excluded from the air the corpse will be maintained for an indefinite period in a perfect and life-like condition, so that it will be prevented from decay and will at all times present a life-like appearance. . . .

In carrying out my process I first surround the corpse 1 with a thick layer 2 of sodium silicate or water-glass. After the corpse has been thus inclosed within the layer of water-glass it is allowed to remain for a short time within a compartment or chamber having a dry heated temperature, which will serve to evaporate the water from this incasing layer, after which molten glass is applied to the desired thickness. This outer layer of glass may be molded into a rectangular form 8, as shown in Fig. 2 of the drawings, or, if preferred, cylindrical or other forms may be substituted for the rectangular block which I have illustrated. In Fig. 8 I have shown the head only of the corpse as incased within the transparent block of glass, it being at once evident that the head alone may be preserved in this manner, if preferred. . . .

DEVICE FOR SHAPING THE UPPER LIP

Filed March 25, 1922

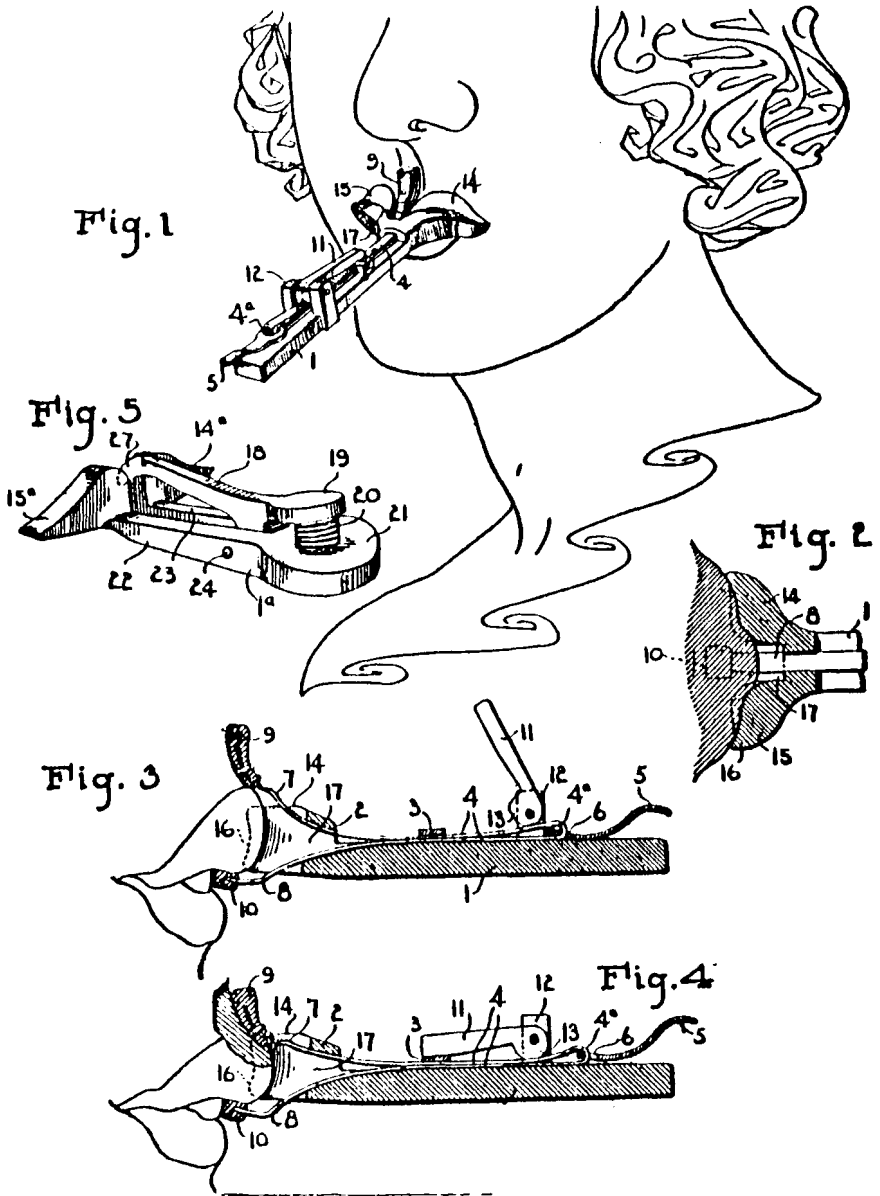

Cupid's Bow Shaper

UNITED STATES PATENT OFFICE
DEVICE FOR SHAPING THE UPPER LIP

Patented June 10, 1924

1,497,842

Application filed March 25, 1922. Serial No. 546,846

. . . This invention relates to devices for re-shaping the upper lip of a person, and has for its object the provision of a simple and easily applied device to re-shape the upper lip of a person to conform to what is known as the "Cupid's bow," whereby it is unnecessary to resort to a surgical operation to produce this effect. . . .

By my new and improved device, I not only cause a depression to be formed in the upper surface and centrally of the upper lip, but the upper lip will be drawn into shaping relation with the matrix whereby the upper lip will eventually be changed to the form of the wellknown Cupid's bow. . . .



GUILIELMUS SALMON.
Medicinæ Professor.
Natus. 7. Junij 1644.

Ars Chirurgica.
 A
COMPENDIUM
 OF THE
 THEORY and PRACTICE
 OF
CHIRURGERY.

In Seven BOOKS.

CONTAINING

- | | |
|--|---------------------------------------|
| I. <i>The INSTRUMENTS and OPERATIONS of the ART.</i> | IV. <i>The Cure of WOUNDS.</i> |
| II. <i>The Removal of DEFILEMENTS.</i> | V. <i>The Cure of ULCERS.</i> |
| III. <i>The Cure of TUMORS.</i> | VI. <i>The Cure of FRACTURES.</i> |
| | VII. <i>The Cure of DISLOCATIONS.</i> |

SHEWING

The Names, Causes, Signs, Differences, Prognosticks, and various Intentions of CURING all kinds of *Chirurgick Diseases*, from Head to Foot, happening to Human Bodies.

To which is Added,

Pharmacopœia Chirurgica; or, The Medical Store, Latin and English: which contains an absolute Sett of Choice Preparations or Medicaments, fitted for the Compleat and Universal Practice both of *PHYSICK* and *CHIRURGERT*.

The whole Work Galenically and Chymically performed.
 The like yet never Published in any Language whatsoever.

BY *WILLIAM SALMON, M. D.*
 Living at the Great House by Black-Friers-Stairs, LONDON.

LONDON, Printed for *J. Dawks*, in *Wardrobe-Court*, in *Great-Garter-lane*: And sold by *S. Sprint*, *G. Conyers*, in *Little Britain*; *Roger Clavel*, in *Fleet-street*; *J. Jones*, and *R. Knapplock*, in *St. Paul's Church-Yard*; *B. Astler* in *Cornhill*; and *E. Tracy* on *London-Bridge*, M. DC. XCVIII.

Instruments shown on Plates I-IX

Plate I

- A.B. Head of Trepan
- C.D.
- E.F. The Male Trepan
- G.H.I. The Female Trepan
- K.L. The Trafine/ Terebellum
- M. The Female Trepan
- N. Forceps
- O. Crows Bill Forceps with Teeth

Plate II

- A.B.D.
- E.F. Terebellum Hildani
- G.H.
- I.K.L.M. Hooks to draw out the
Dead Child
- N. Lenticular
- O. Rasour Knife or Pen Knife
- P. Cranes Bill Forceps - Straight

Plate III

- A.B. Seton Forceps
- C.D. Seton Point
- E. Actual Seton Cautery
- F. Seon Needles
- G. Dismembring Pincers
- H. The Gouge or Hollow Chizel
- I. Dismembring Shizel
- M. Lapidillum
- K. The Mallet or Hammer
- L. Small Head Saw

Plate IV

- A. The Catheter
- B. Goose Bill Spatula
- D. The Director
- E.
- F.G. Goose Bill Forceps
- H. The File
- I.K. Myrtle Leafed Pen Knife
- L.M.
- N.O. Needles for Couching Cataracts
- P.R. Seton Forceps

Plate V

- A.B. The Spatula
- C. The Stitching Quill
- D.E. Speculum Lingue
- F.G. The Rasour
- H.I. The Head Saw
- K. The Membrane Preserver
- LL. The Levatory
- M. Crows Bill Forceps with Teeth
- N.O. Small Probes
- Q.P.
- R. The Scissers
- S.T. Cautery for the Ranula

Plate IX

- The Ear & Yard Syring
- The Womb Syring
- The Clyster Syring
- The Fistula Syring

Plate VI

- A.B.C. Aetual Cauteries
- D.E. Needles for Wounds
- F. The Insision Knife
- G.H.I. Goose Bill Forceps
- K. Hollow Scraping Levatorie
- I.L. Cranes Bill Forceps - straight
- M.N. The Levatory
- O. The Wound Hook
- R. Spoon Catheter
- Q. Uvula Spoon

Plate VII

- A.B. The Head Saw
- C. Speculum Matricis
- D.E.F. Pliers with a Screw
- G. The Pliers
- H. The Dilatatory
- I. The Lenticular
- LLK. The Trafine
- O.P. Syringotomus
- M.N. Hook to Draw Stones

Plate VIII

- A.B.C. Aetual Cauteries
 - D. Dismembring Chizel
 - E.F. The Dismembring Saw
 - F. The Dismembring Knife
 - G.H. Dismembring Chizels
 - I.K.L. Needles for a Hare Lip
 - M.N. Speculum Ani
 - P.Q.O. Speculum Oris
-

Tab. I.

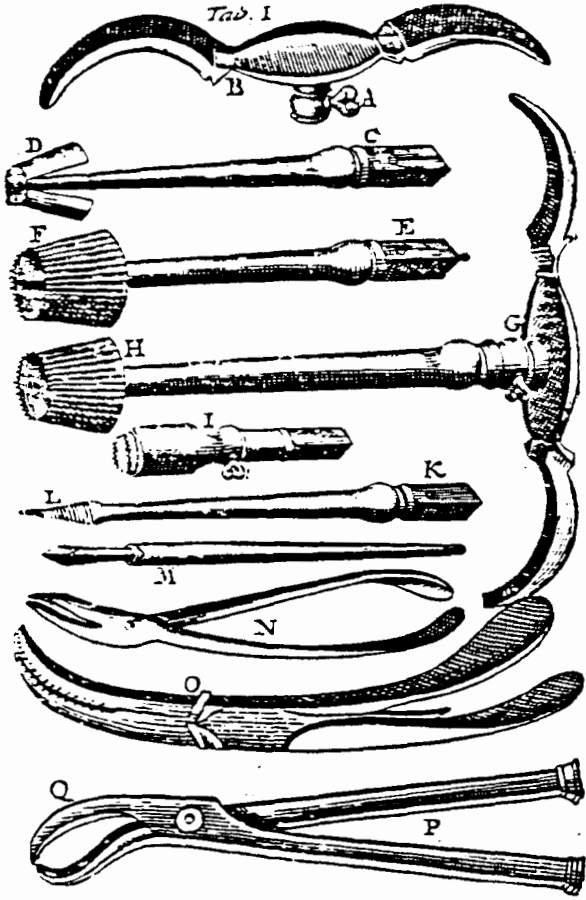

Tab. II.

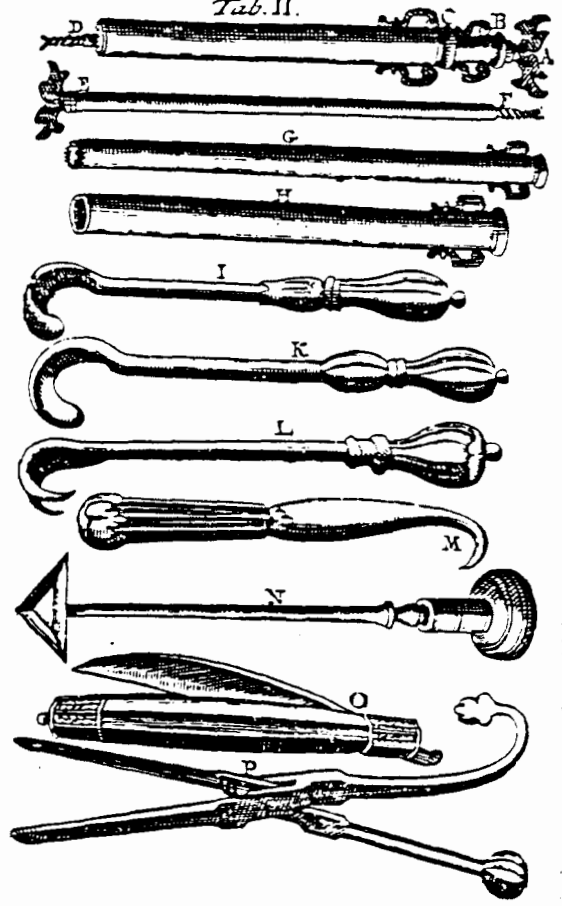

Tab. III.

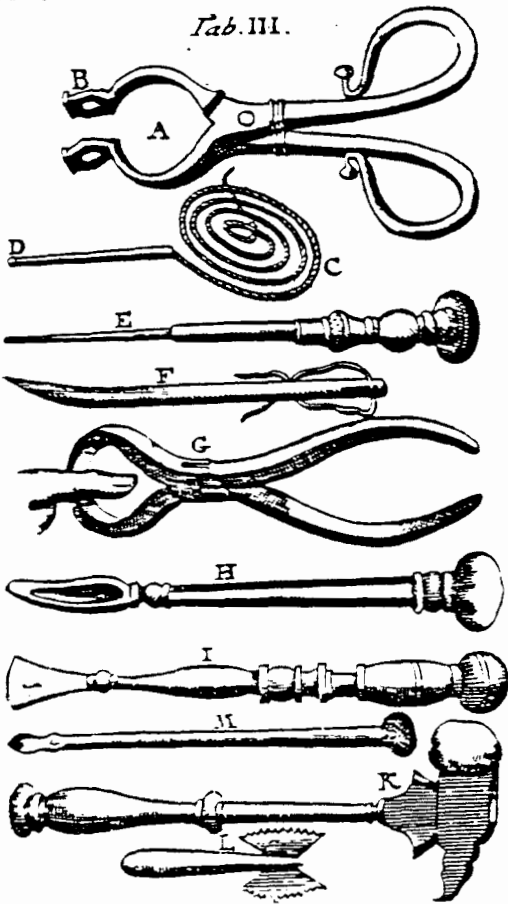

Tab. IV.

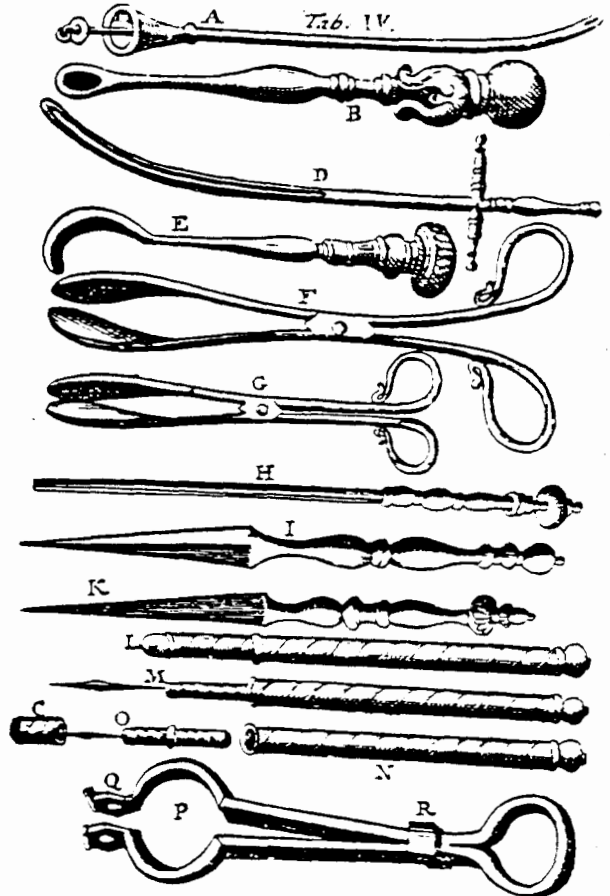

Tab. V.

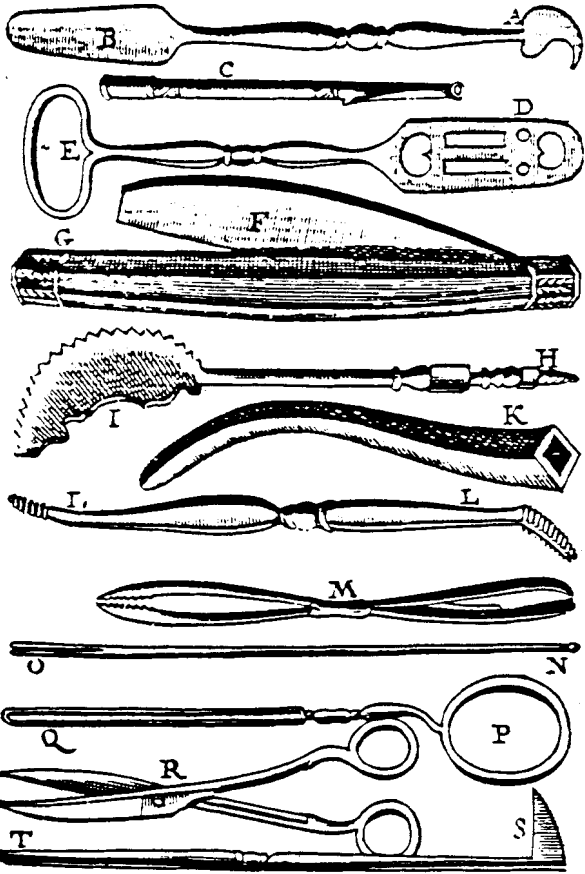

Tab. VI.

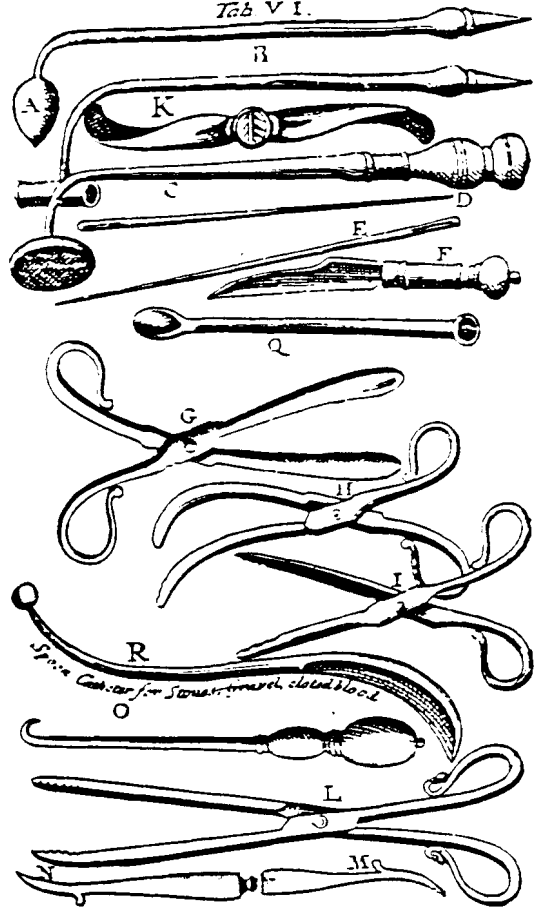

Tab. VII.

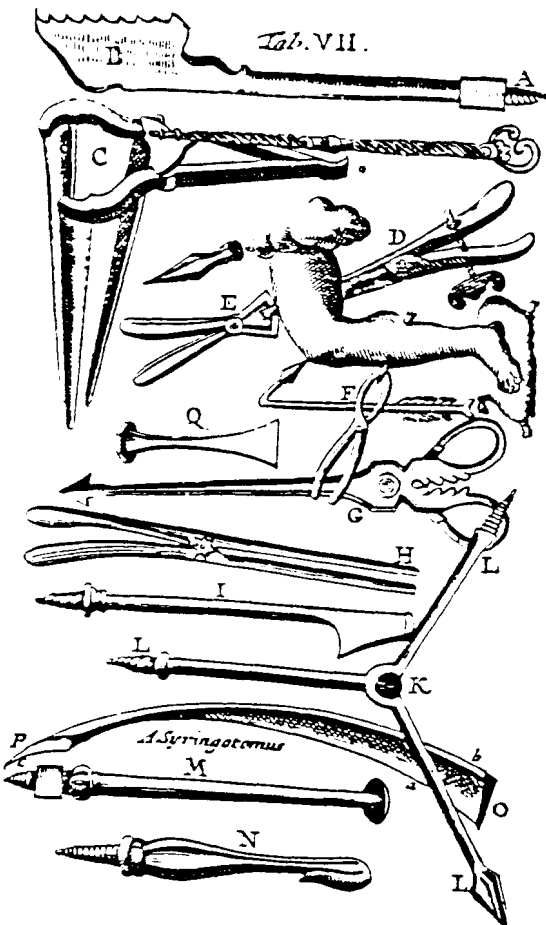

Tab. VIII.

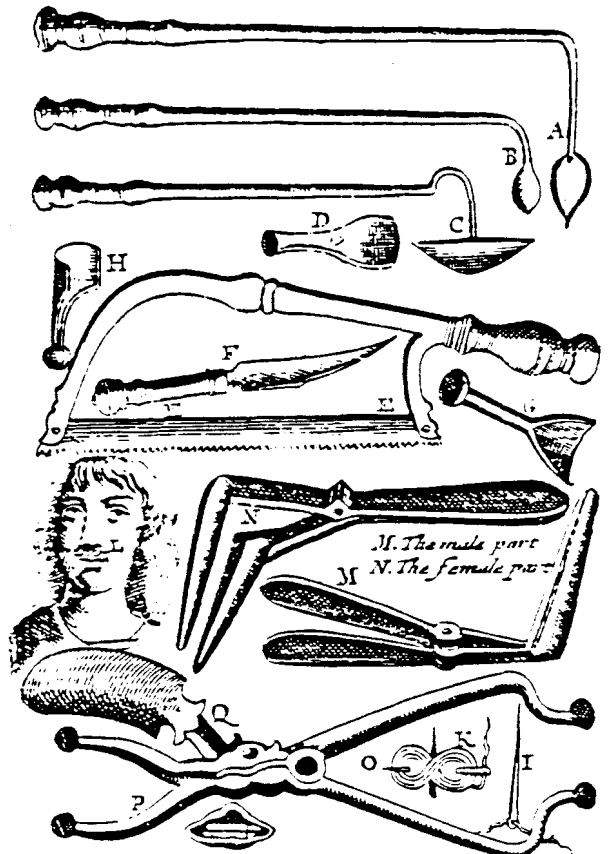

Tab. V.

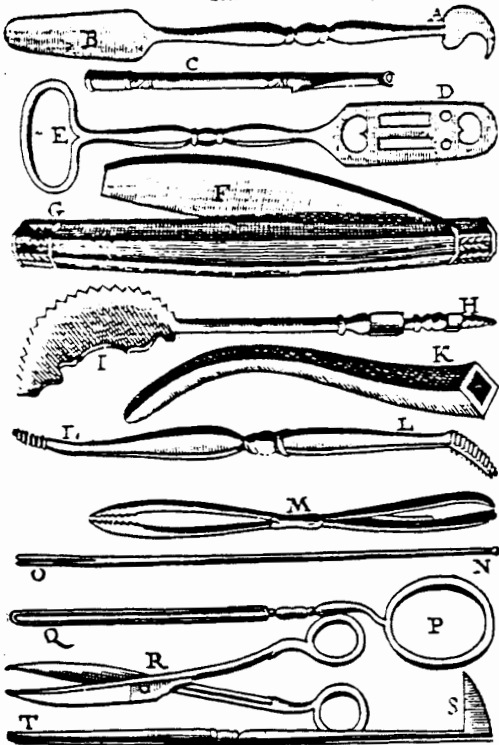

Tab. VI.

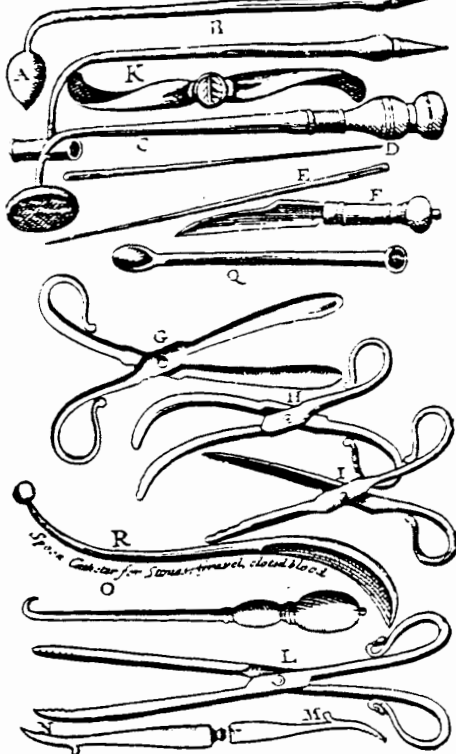

Tab. VII.

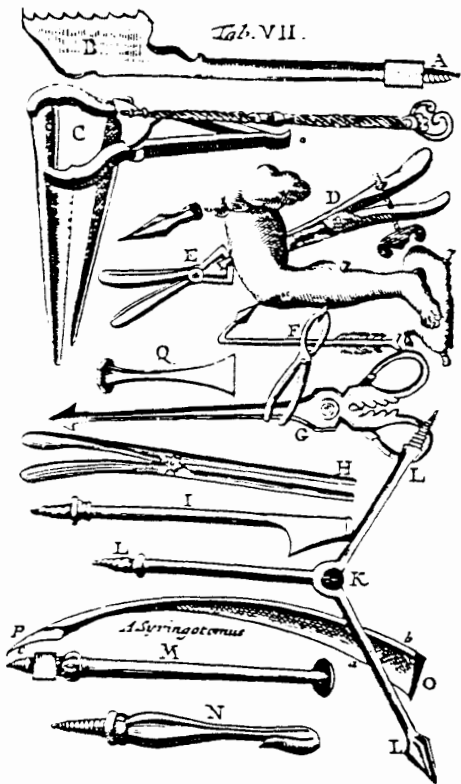

Tab. VIII.



TAB. IX.

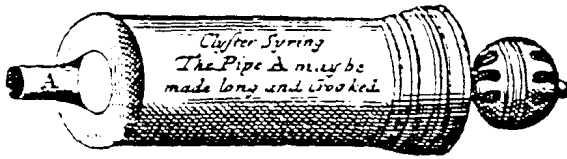
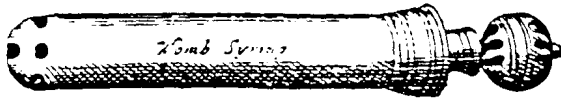
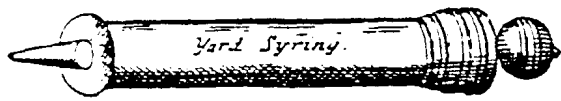

Muſc. and Forceps for scraping of Teeth

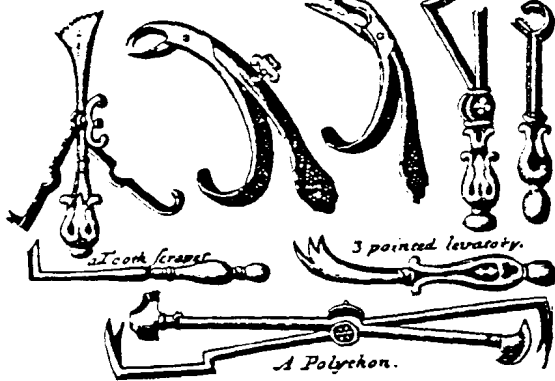

TAB. X.

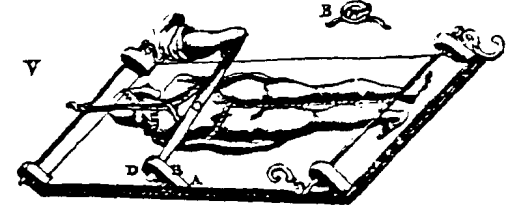
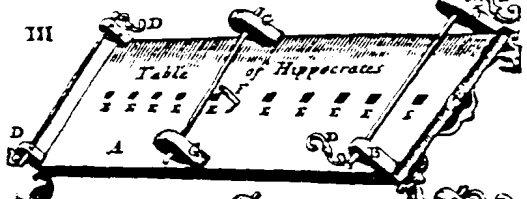
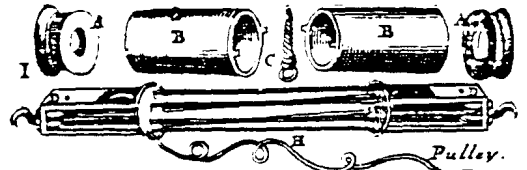

TAB. XI.

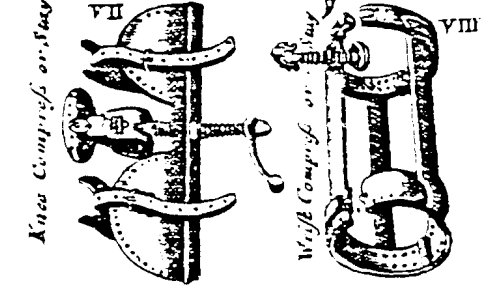
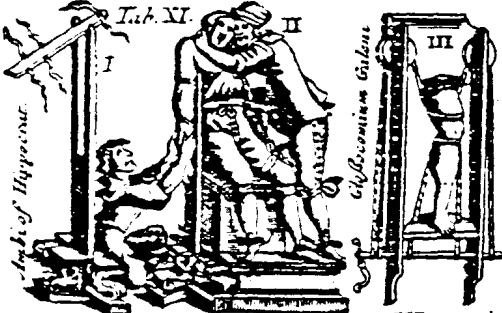

TAB. XII.

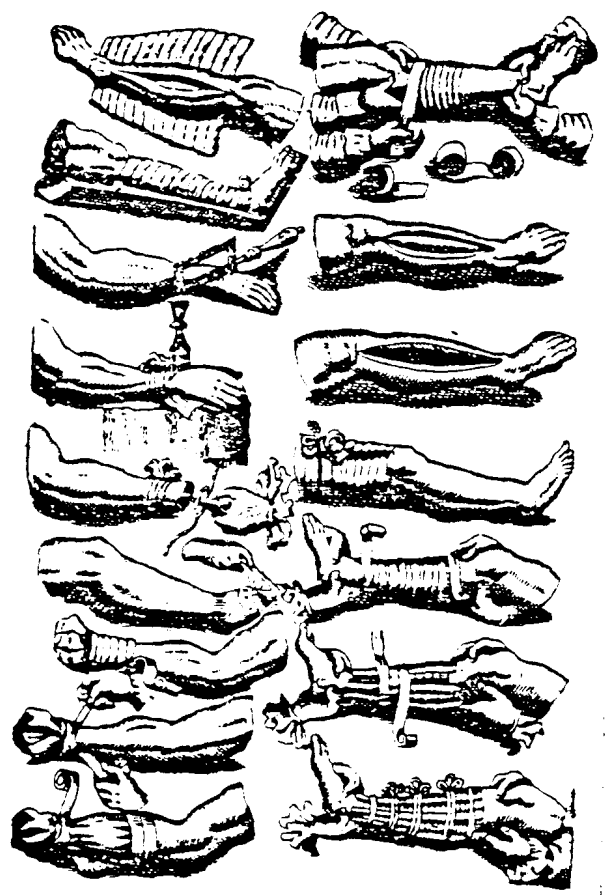

MECHANICAL THERAPEUTICS.

A

PRACTICAL TREATISE

OR

SURGICAL APPARATUS, APPLIANCES,

AND

ELEMENTARY OPERATIONS;

EMBRACING

BANDAGING, MINOR SURGERY, ORTHOPRAXY, AND THE
TREATMENT OF FRACTURES AND DISLOCATIONS.

BY

PHILIP S. WALES, M. D., SURGEON U. S. N.

WITH SIX HUNDRED AND FORTY-TWO ILLUSTRATIONS.

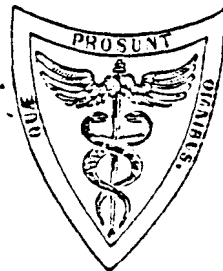

PHILADELPHIA:
HENRY C. LEA.
1867.

CHAPTER XI.

BLOODLETTING.

BLOODLETTING is an operation performed for the purpose of diminishing the quantity of blood in the system, with a view of relieving or curing diseases.

It may be drawn from the arteries, veins, or capillaries; in the first two instances the bleeding is said to be *general*, and in the latter, *local*.

The former plan, now almost abandoned, is had recourse to when the amount of blood to be drawn is large, and a decided effect is to be made upon the system; and the latter, when the object is rather to deplete a certain organ or part, without reference to the system at large.

There are cases, however, where both methods may be employed together with advantage.

SECTION I.

GENERAL BLEEDING.

VENESECTON, OR PHELEBOTOMY.—In former times bleeding was performed upon most of the large veins, the operation in each particular case being supposed to possess some peculiar advantages; but

at present the physician, knowing that the general character of the effects of loss of blood is the same whether a vein be opened in the arm, in the neck, or in the leg, selects the most convenient place for the operation, and general experience has decided that to be the bend of the elbow. Here the veins are moderately large, superficial, and easily dilatable by a bandage placed upon the arm.

By reference to the annexed wood-cut, Figs. 552 and 553, showing the veins of the bend of the elbow, it will be seen that there are five

Fig. 552.

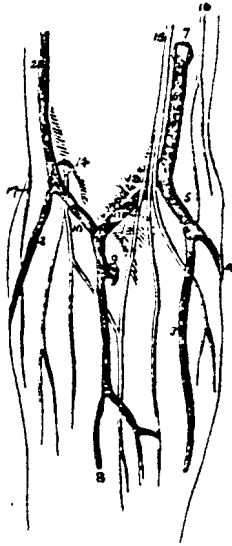

Fig. 553.



Anatomical relation of the veins in the bend of the elbow.

vessels from which the surgeon may draw blood: the radial vein (1) is on the outer side of the forearm, between the skin and superficial fascia, is crossed by (17) the spiral cutaneous nerve, a branch of the musculo-spiral, and is surrounded by a large number of nervous filaments; the median (8) is about midway of the upper part of the forearm, and divides above into two branches, one going to the cephalic (2), forming the median-cephalic (10), and the other to the basilic, forming the median-basilic (11); the anterior (3) and posterior (4) ulnae are upon the inner side of the arm, and join above in a common trunk (5), which empties into the basilic; the median-basilic crosses the brachial artery, separated from it by a slip of fascia from the tendon of the biceps (13) at the point marked by the figure 12, which rests upon the deep fascia; in Fig. 553 this fascia is turned back, exposing the artery beneath; the internal cutaneous nerve (15) divides into several branches, which pass across the median-basilic: the external cutaneous nerve (14) pierces the deep fascia, and, dividing into two branches, passes behind the median-cephalic, which is surrounded by several nervous filaments: the intercosto-humeral cutaneous nerve (16) runs along the outer side of the basilic.

The veins are more or less surrounded with nervous filaments, so that it will be impossible to avoid wounding some of them in venesection, nor does experience teach us that it is of much consequence if they are. The proximity of the median-basilic to the brachial artery should put us on our guard when opening that vein; and, indeed, if there is any choice offered, it should be avoided altogether. The posterior ulna is sometimes quite large, and offers then the most eligible spot for the operation; though, upon the whole, the median-cephalic will be the safest and most convenient vein.

If a sudden impression is desired to be made upon the system, and syncope is induced, the patient should be bled in the erect posture; while, on the contrary, if the full depletive effects of the operation are sought, he must lie down.

After the surgeon has selected the vein he intends to open, which is ordinarily visible through the skin (though in children and corpulent persons it is not always so, and then the sense of touch will enable us to make out the position of the vessel), the circular bandage is placed around the arm, some distance above the elbow; this consists of a strip of muslin one and a half inch wide and a yard long, and is applied by placing its body upon the front of the arm, conducting its extremities around the limb, and finally bringing them forwards again to be tied in a single bow-knot upon the outer side of the arm.

The bandage should be drawn sufficiently tight to arrest the circulation in the veins without disturbing that in the arteries; the surgeon then takes the lancet by its blade between the thumb and index finger, while the middle finger, resting upon the forearm, supports the

Fig. 554.

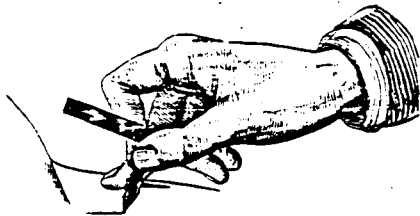

Mode of holding the thumb-lancet in bleeding.

hand, as seen in Fig. 554; with the left hand the forearm is grasped in such a manner that the corresponding thumb may be used to steady the vein, while it is being punctured. The point of the thumb-lancet is now thrust forwards obliquely, by simply extending the thumb and finger, into the cavity of the vein, which is known by the absence

of further resistance to the progress of the instrument, and then withdrawn by slightly elevating the point to enlarge the orifice to the desired extent. If the operation is well done, the blood will flow in a continuous stream, and should be caught in a common basin, or in one of those graduated vessels especially made for this purpose, and called a "palette."

Should the blood not flow freely enough, the patient may be directed to grasp something in his hand, and to close and relax the fingers alternately. The exit of the blood may be hindered by the loss of parallelism between the incision in the skin and wall of the vein, caused by some movement on the part of the patient; to remedy this the limb should be restored, as nearly as possible, to the position in which it was when the incision was made; or a little clot of blood or

granule of fat may come between the lips of the little wound; they must be removed with the point of a probe or a pair of forceps. In case the ligature upon the arm is drawn so tight as to obstruct the passage of the blood from the arteries to the veins, it must be promptly loosened until the blood issues freely. The desired amount of blood having been drawn, the surgeon places his left thumb over the incision, removes the circular bandage from the arm, which should be cleansed from blood with a moist sponge, and slips beneath the thumb a small compress an inch square by half an inch thick, made of a piece of linen folded; the compress is secured in position by the figure of 8 bandage of the elbow, taking care to draw its lower convolutions tighter than the upper ones that efficient pressure may be made upon these veins anastomosing with the vessel opened. The arm is now flexed at a right angle, and supported in a sling depending from the neck, for thirty-six or forty-eight hours, when the wound will be found cicatrized.

Should it be necessary to repeat the bleeding within the twenty-four hours, the same vein may be again opened with the point of a probe; or if this has been anticipated, a little piece of simple cerate placed between the margins of the incision will prevent its healing, upon the removal of which the blood will flow freely; but it is a better plan always to make a fresh incision.

The spring-lancet is sometimes employed in venesection; the instrument consists of a blade or fleam inclosed in a metallic case, and acted upon by a strong spring; when in use the blade is drawn up with the handle projecting above it until its point is above the lower edge of the case, in which position it is held by a trigger, and not permitted to be driven down unless the button upon the side of the case is pressed upon. The arm having been prepared in the same manner as in the previous case, if the vein is superficial the edge of the fleam should be held a little above the skin; but, on the contrary, if it is deep seated, the point of the fleam ought to touch the surface, in order that the cavity of the vessel may be surely reached; the blade is then driven into the vein obliquely by pressing the button of the spring, and quickly withdrawn.

Some accidents have followed venesection which require notice in this place, as great alarm has often been caused the patient, where there has been no occasion for it, by some unusual complication of little moment; for instance, the cutaneous incision may be very narrow, or lose its parallelism with the perforation in the wall of the vein, so that the blood escapes into the cellular tissue, and gives rise to an ecchymosis several inches around the puncture; the blood in this case will be absorbed in three or four days. From the same causes the blood may

Fig. 555.

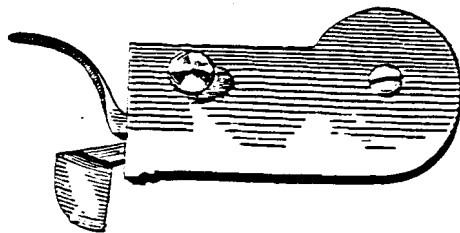

Spring-lancet.

coagulate around the vein, forming a tumor called a thrombus, which also usually disappears without any bad consequence, though it may excite inflammation and suppuration, and demand the use of the lancet to evacuate the pus.

As the veins are surrounded more or less with nervous filaments, some pain may be caused in irritable subjects, which may be removed by the application of the watery solution of opium; convulsions and tetanus have been stated to have originated from the same cause.

As inflammation of the lips of the wound, phlegmon, erysipelas, and angeioleucitis, may happen from special causes in any sort of wound, they are simply mentioned here as having been occasionally seen to follow venesection.

Phlebitis is always a serious complication of wounds, and may occur in phlebotomy; the veins become hard like cords, and the whole limb œdematous. The proper remedies for phlebitis are the application of leeches, and, after their removal, narcotic poultices. It has been recommended to tie the vein above the puncture to prevent the pus getting into the circulation; with the same view Abernethy advised the vessel to be divided instead of ligatured; free incision at the seat of the wound, combined with pressure, will also be found advantageous.

Puncture of the tendon of the biceps muscle has also been pointed out as a redoubtable accident upon insufficient grounds.

Wounding the brachial artery in venesection has often occurred, and may result in either traumatic aneurism, or aneurismal varix; the blood, in the former instance, being poured out into the surrounding cellular tissue, and in the latter into the cavity of the vein through the orifice made in its posterior wall by the lancet. In the aneurismal varix the blood will issue in jets, or per saltum, as it is called, and be of a scarlet color, and somewhat frothy. Pressure upon the brachial artery above arrests the hemorrhage at once; but not at all, or very slowly, if the pressure is made upon the entire circumference of the limb. The pressure should be exerted upon the artery in the axilla, that no mistake can occur from its bifurcation taking place high up the arm. From these symptoms, if it should be ascertained that the artery has actually been pierced with the lancet, the arm should be inclosed in a roller bandage from the fingers to the shoulder, and a graduated compress placed over the puncture, with

Fig. 556.



Mode of arresting hemorrhage from the brachial artery at the bend of the elbow, after venesection.

its apex downward, in the manner shown in Fig. 556; *a*, is the artery, and *b, b* the compress. To sustain the compress, apply over it a figure of 8 bandage pretty firmly.

By this treatment it sometimes happens that the wound in the artery cicatrizes in three or four days, and no further trouble is experienced; under other less favorable circumstances, a pulsating tumor is formed, which will demand an incision to be made over the bleeding artery, and a ligature applied above and below the wound.

Both the salvatella and cephalic veins of the hand have been opened in venesection. A circular bandage placed around the wrist with sufficient firmness, will cause them to swell sufficiently, so as to be easily punctured with the lancet. Should the ligature not render them prominent, the hand may be soaked a short time in warm water. There are no arteries in the way, and the only caution necessary is to avoid wounding the sheaths of the extensor tendons. When the radial artery, instead of following its usual course, mounts over the extensors of the thumb, it will be found running parallel with the cephalic vein.

The cephalic vein of the arm is found between the deltoid and pectoralis major, and may be exposed by an incision an inch long in front of the shoulder, over the inter-muscular space. Velpeau recommends the vein to be sought just above the inner condyle, where it is more superficial; bleeding from this vessel is rarely ever practised at present.

It was formerly recommended, in certain cases of cephalic disease, to bleed from the external jugular which crosses the neck obliquely, lying between the superficial fascia and the platysma myoid muscle, and empties in the subclavian behind the clavicle. The operation is performed by placing over the vein a compress just above the clavicle, and confining it in the position with a cravat, the body of which is laid over the compress, and its tails tied beneath the axilla of the opposite side, in order to prevent the return of the blood in the vessel. (Fig. 558.) The point that should be selected for the puncture is just below the middle of the vein, where the vessel is largest,

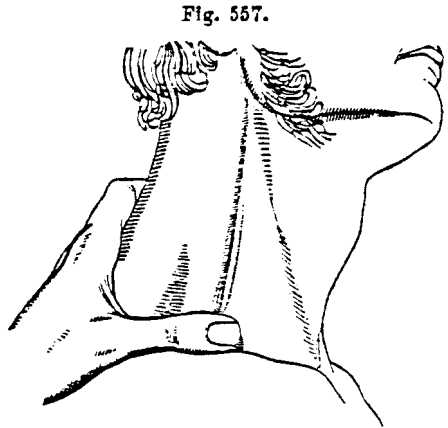

Bleeding at the jugular vein.

and surrounded with fewer nervous filaments. The vein must be steadied by the thumb (Fig. 557), while the thumb-lancet, held in the right hand in the manner we have described, is thrust into its cavity in an oblique direction, so as to cut the muscular fibres of the platysma at right angles to their course, that their retraction may allow a sufficient opening for the blood to flow out freely. A card or piece of tin, bent in the shape of a gutter, and placed below the point of puncture, will conduct the blood away into a vessel ready at hand to receive it.

Should the blood not issue with sufficient rapidity, the patient may be directed to perform the movements of mastication, which will force the blood from the deeper veins into the more superficial ones.

To arrest the bleeding, place the finger over the puncture, remove the compress and bandage at first applied, and put a compress upon the wound to which it must be secured by a cravat, the base of which is laid upon the neck and shoulder of the opposite side, its tails crossed over the compress, and finally tied together beneath the axilla of the side upon which the vein was punctured.

The veins of the foot are small, and therefore ineligible for venesection; by their junction, however, they form two large trunks, the internal and external saphenous, which may be opened with the lancet. The external saphenous is situated between the external malleolus and the tendo-Achillis, and is in relation with a nerve of the same name; the internal saphenous lies upon the inner malleolus between the skin and periosteum; this vein is larger than the former, and is generally selected for the operation.

To enlarge the veins about the ankle, the foot must be placed in warm water, and a circular bandage applied to the leg three or four inches above the malleoli, then the most prominent vessel being selected, it is steadied with the thumb of the left hand which grasps the foot, while the point of the lancet is shoved into its interior with the fingers of the right hand, almost parallel with the vessel, in order to avoid penetrating the periosteum or bone. The flow of blood may be increased by keeping the foot immersed in warm water contained in a pail, though it has the disadvantage of interfering with a correct estimate of the amount of blood drawn; the bleeding may also be accelerated by the patient moving his toes.

When a sufficiency of blood has been obtained, the circular bandage is removed, and a compress confined over the wound with the figure of 8 bandage of the ankle.

If the point of the lancet should, by any accident, penetrate the bone, the wound may be enlarged a little and the point removed; though should the little fragment of metal be permitted to remain it will, perhaps, cause a phlegmon to form, and be finally eliminated with the pus.

ARTERIOTOMY.—The only artery that has been opened in later times for surgical depletion is the temporal, and that is now nearly abandoned by most surgeons; the ancients, besides this one, did not fear to cut the mastoid, and even the radial.

If it is ever desirable to perform this operation upon an artery, the anterior branch of the temporal is of sufficient size to afford the requisite amount of blood, besides possessing the advantages of being superficial and easily compressed upon the temporal bone to check the hemorrhage; and there are no important parts adjacent that we need fear wounding.

The operation is performed either with a lancet or a bistoury (Fig. 553). The artery being held by the index and middle fingers, an incision is made three-fourths of an inch long, at right angles with its course.

Fig. 558.

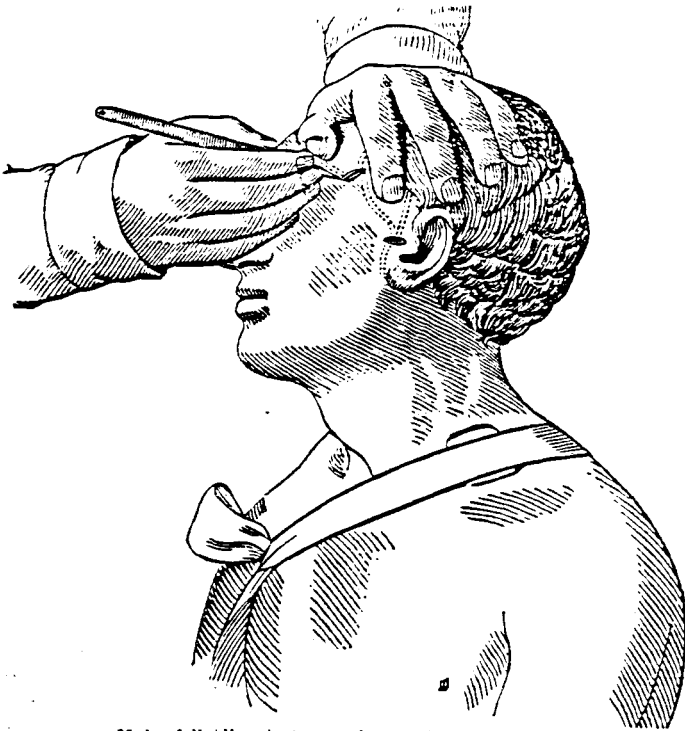

Mode of dividing the temporal artery in arteriotomy.

dividing half the diameter, or thereabouts, of the vessel. The object of this is to prevent the retraction of the extremities of the artery, which would be likely to defeat the aim of the surgeon, inasmuch as the orifices would then be drawn into the cellular tissue, in which the blood would coagulate and seal them up.

When the bleeding has gone far enough, the instrument is used again to cut the vessel completely through to permit the divided ends to retract; a compress is placed over the wound and supported by a roller bandage, as seen in Fig. 559.

The artery is usually obliterated in eight or ten days, though a traumatic aneurism does sometimes result, requiring the ends of the artery to be tied.

Fig. 559.



Bandage and compress applied after arteriotomy.

SECTION II.

LOCAL BLEEDING.

Local bleeding is generally performed over, or as near to the diseased part as possible, for the purpose of abstracting blood directly from it. In some cases, from necessity, the point upon which the operation is performed will be more or less remote from the diseased organ, as in the abstraction of blood from the temple in diseases of the eye, and from the hæmorrhoidal vessels in affections of the brain. The first method is by far the most serviceable and the one commonly employed in surgical practice.

Local depletion may be effected in two modes: first, by cupping; and second, by leeching.

1. Cupping consists in the application to the skin of a bell-shaped vessel, now made of glass, technically called a "cup," by rarefying the air contained within it by means of heat, or a sort of air-pump. In this way the integuments are made turgid and red, and are forced up some distance into the cup by atmospheric pressure.

This action produces a derivative effect by drawing the blood from the morbid tissues beneath, whose capillaries are thereby placed under more favorable circumstances for restoration to health; this is called *dry cupping*.

If a more decided and permanent derivative effect is required, the integuments are scarified so that, upon the reapplication of the cup, the blood will flow out from the capillaries freely, constituting *wet cupping*, or, as it is sometimes named, *cut cups*.

Cupping glasses are usually supplied, by surgical instrument makers, of different sizes, holding from one to four ounces, destined for application to the various localities of the body, upon all of which it would be impossible to put glasses of the same dimensions. Should these not be at hand, however, the ordinary wineglass or tumbler will answer as a good substitute.

The person to be cupped should be placed in a convenient position, and arranged in such a manner that his clothes may not be soiled with the blood; the skin upon which the operation is to be performed is then bared and wiped clean with a sponge dipped in hot water, which will at the same time tend to congest the capillaries, and thus render the bleeding freer. The operator takes a cup in his hand, and either dips it in hot water, or holds it for two or three seconds over the flame of a spirit lamp, to rarefy the air in its interior, and quickly claps it upon the skin; a better plan is to moisten the interior of the glass with alcohol, or put into it a thin piece of paper dipped in that fluid and set fire to before the cup is applied.

The integuments will rise immediately into the mouth of the glass, and present a red, turgid appearance.

A second mode of rarefying the air inside the cup is with an air-pump, which is made with a socket at its extremity to fit the nipple-like projection upon the tops of the glasses; the projection is pierced with a small aperture and covered with a little slip of gold beater's

skin or oiled silk to serve as a valve, or, as a better arrangement, still it bears a stopcock, as seen in Fig. 560. With this instrument the air is gradually exhausted from the glass by repeated strokes of the piston, until the skin is sufficiently turgid, when the stopcock must be turned, and the air-pump removed.

To do away with the inconveniences of the air-pump, among which we may mention as the chief its liability to get out of order, it has been suggested to attach an India-rubber ball to the top of the cup and make the vacuum with that, by grasping the ball in the palm of the hand and alternately compressing and relaxing the hold upon it (Fig. 561).

Whichever plan is pursued, the glasses must not be exhausted too much, for if they are, their edges will pro-

Fig. 561.



Cupping-glass with India-rubber ball attached.

Fig. 560.



Mode of attaching an air-pump to the cupping-glass.

bably bruise the skin, prevent the flow of blood, and at the same time cause considerable pain.

To remove the cup it will be necessary simply to cant it a little to one side, and with the tip of the finger press the integuments away from any point of its rim, which will permit the entrance of air into the glass and destroy the vacuum.

In applying cut cups the same methods are pursued as described above, and when the skin is sufficiently congested the glass is removed and incisions are made upon the reddened surface; this may be accomplished either with the lancet, bistoury, or *scarificator*, the latter being the most expeditious and least painful manner. This instrument, as seen in Fig. 562, consists of a square metallic case containing from twelve to fifteen broad, sharp blades, attached to two stems of metal revolving through a quarter of a circle, and driven by a strong spring; the depth of the cut may be graduated by raising or depressing the blades with the screw-head seen upon the top of the instrument; the blades are drawn into the case by

Fig. 562.

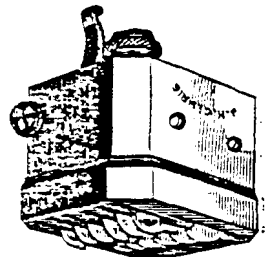

Scarificator.

pulling back the lever placed by the side of the screw-head; the lever is held by a catch.

The instrument thus arranged is ready for use, and is laid flat upon the surface to be scarified; then, by exercising pressure with the thumb upon the little button seen upon its side, the trigger is sprung, and the blades driven into the skin.

After the incisions are made, the glasses are again applied, when the blood will readily flow into them in quantity varying with the size of the cups and the vascularity of the parts; perhaps, on an average, an ounce will be drawn by each cup, but should it be necessary these may be reapplied several times, until the desired amount of blood is obtained. A basin of warm water should be at hand, and two or three soft towels and sponges; the cups, one after another, are then seized in the fingers, and having been depressed upon the side, are quickly removed with a sort of scooping motion to catch the clotted blood, assisting the operation with a sponge held in the opposite hand. In this manner the patient's clothes will not be soiled at all. The surface may be now gently cleansed with warm water, and dried with a towel; generally, no dressing will be required, but should the incisions be sore or painful, a soft rag, moistened in glycerine, or water-dressings, will be the most appropriate applications.

Cups should not be placed over osseous projections, nor indeed upon any surface where there is not a sufficient amount of soft tissue to give them ample support. There are other situations where their application is manifestly impracticable—as in the interior of cavities, upon the eyelids, testicles, &c. Yet even these difficulties have been surmounted in some degree by the cups of Toirac, which consist of long, narrow glasses, connected by an elastic tube with an air-pump, that are capable of being applied to the bottom of any cavity whatever. M. Sarlandière invented an instrument called a *odellomètre*, which combines in its construction the air-pump cupping-glass with the scarificator, so that the whole operation of cupping can be accomplished in one application of the instrument.

Prof. Simpson, of Edinburgh, has used an instrument for cupping the interior of the uterus in amenorrhœa; it consists of an air-pump and a perforated tube, sufficiently large to hold several drachms of blood, connected together. The tube is curved, and has a ring of gutta-percha upon it, rounded in such a manner as to accurately close the os uteri when the point of the instrument is in the cavity of that organ.

M. Junod recommended the use of cups sufficiently large to inclose portions of the body, as the leg or arm. He employed a copper cylinder, in which the limb was to be placed, and rendered air-tight by a strip of India-rubber surrounding the limb and the upper end of the cylinder; to the latter an air-pump is attached to make the vacuum, which can be regulated by an instrument connected with the cylinder. With this apparatus the most powerful and rapid derivative effects can be obtained, that syncope may be induced in a brief space of time.

LEECHING.—For the purpose of local depletion, leeches, in many

cases, offer decided advantages; indeed, some parts of the body, from their situation within the interior of the natural cavities, peculiarity of form, or from diseased condition of their surfaces, cannot be easily depleted in any other manner. There are two kinds of leeches employed in this country, which it is necessary to be able to distinguish, as they differ materially in the amount of blood which they are capable of abstracting. The foreign leeches (*Sanguisuga officinalis* and *medicinalis*) are gathered in Sweden, and several parts of the south of Europe, from the marshes and running streams, and imported from London and Paris. They vary from two to four inches in length, and are marked upon their backs, which vary from a blackish to a grayish-green, with six longitudinal ferruginous stripes, the four lateral ones being interrupted with black spots; the belly, in one variety, is of a yellowish-green color, bordered with longitudinal black stripes; in the other, of a green color, bordered and spotted with black. Each of these animals will draw rather more than a half-ounce of blood.

The indigenous leech (*Hirudo decora*) is usually from two to three inches long, though it sometimes attains a length of five inches; its back is of a deep green color, with three longitudinal rows of square spots, and the belly of a brownish-orange color, irregularly spotted with black. The animal does not make so large a wound in the skin as the former, and it requires at least six of them to extract one ounce of blood.

The mouth of the leech is placed in the centre of the anterior disk, and is composed of three cartilaginous jaws, each armed with two rows of fine teeth meeting in such a manner as to make a triangular wound in the integuments.

In applying the animals to the skin, care should be taken to have it well cleansed of all foreign matters clinging to it either from the applications that may have been used, or from the secretions; the hairy parts of the body should be thoroughly shaved, so that the hair may neither interfere with the action of the leeches nor become clotted with blood.

The leeches are then put on inclosed in a tumbler; or, if there are many of them, laid first upon a napkin spread upon the palm of the hand, and then clapped to the skin, the fingers being used to hold the edges of the cloth all around, so that they may not escape. Vigorous leeches will generally take hold upon the skin without delay; but should they not do so, milk, cream, or sweetened water smeared over the surface will almost always tempt them to bite: some persons obtain a little blood from the tip of the finger by pricking it with a needle, which they rub upon the skin with the same object.

An increased activity may be excited in the leeches by covering them with a cupping-glass, and rarefying the air contained in it by a few strokes of the air-pump. Another mode recommended as very efficient is to put the leeches first in a tumbler half full of cold water, and by a quick movement invert it over the part to be depleted; the animals will seek the warm skin immediately, and quickly attach themselves to it, when the water may be permitted to run from the glass upon cloths placed to receive it.

To bring leeches in contact with the interior cavities, the vagina or rectum, for instance, a speculum should be first introduced, then a leech is placed in a glass tube, or one formed from paper or a card; and when its point is at the spot where the animal is to bite, the latter should be shoved forward against it by a pencil, or little stick running through the tube: the tube may also be employed to bring the mouth of the leech in contact with any part of the buccal or nasal mucous membranes.

When the leeches are gorged, they will generally relax their hold and drop off, though should it be necessary to arrest their action at an earlier period than that, a little salt, snuff, or ashes, may be sprinkled upon them; no tractile force should be exercised for this purpose, as it is calculated to damage the jaws of the leech, and leave a portion of the suctorial apparatus sticking in the skin.

It has been proposed, in order to increase the capacity of the leech for drawing blood, to clip off the point of his tail, after he is gorged. The operation is rarely successful, and always fatal to the animal; besides, after the leech falls off, the bleeding may be continued by the application of warm water-dressings, poultices, or a cupping-glass, so that really there is no necessity for this barbarous treatment.

In some instances the hemorrhage continues after the leech-bites have been exposed to the air without any of these warm applications, and to such an extent as to call for the interference of the surgeon. Generally, the compression exercised upon the wounds by a little cone formed by twisting a piece of lint or charpie, and a roller bandage, will suffice to stop the bleeding. Another efficient remedy is the introduction of the fine point of a stick of nitrate of silver into the bite: others have found it necessary to employ the actual cautery or the twisted suture, before the hemorrhage could be arrested; such cases must be rare, and mostly occur in persons of the hemorrhagic diathesis.

Saturated solutions of alum, of sulphate of zinc, the liquor of the persulphate of iron, and other astringents, are also efficient applications, and may be used upon pledgets of lint thrust into the wound with a needle, and supported with a compress and roller.

Accidents have happened from the leeches getting into the stomach and rectum, as in the cases observed by Baron Larrey, where they were swallowed with the water that soldiers drank from the pools in Egypt. They have also been known to detach themselves from the nasal and buccal mucous membranes, and escape into the stomach. The remedy in these cases is the prompt administration of salt water or vinegar in the form of a drink, or as an injection if the animals have crawled into the rectum.

Wounds of the temporal artery and external jugular vein have been seen to result from leech-bites; compression will succeed in arresting the hemorrhage from those vessels.

The classes of cases in which leeching is employed, are in the treatment of the inflammatory diseases of infants where abstraction of blood is indicated, and in whom general bleeding cannot be performed with safety; and in the local inflammations of the various organs of the body, in which leeching is both depletive and counter-irritant. In

phlegmonous erysipelas it has been advised to abstain from the use of leeches, upon the supposition that their bites would add to the severity of the malady; but the objection does not appear to be sustained by actual observation.

The arrangement and care of leeches is an important matter, and deserve a moment's consideration. After the animals have been once applied, the blood may be removed from their stomachs by throwing them into a solution of common salt, sixteen parts to a hundred parts of water; then remove them one by one, and holding the animal by the tail in water that feels hot to the hand, draw him gently through the fingers to expel the blood. After this treatment they should be placed in clean, fresh water, which must be changed once a day; on the eighth day, they may again be used when required.

Leeches are liable to epidemic diseases, which destroy them rapidly; and the best means to preserve them from these, as well as to sustain them in vigorous health, is to place them under those natural conditions, as near as can be, in which they are found. For this purpose numerous methods have been suggested, of which the simplest is, to select a jar in which soft clear water is put, throw the leeches into this, and keep the jar covered with a linen cloth; the water must be changed twice a week in winter and once a day in summer, care being taken that all slimy matter adhering to the animals is removed.

In a state of nature leeches clean themselves of this slimy material, upon the freedom from which their health so much depends, by crawling through the interlacing mosses of the marshes in which they live.

To furnish a condition analogous to this, it will be advisable to put in the bottom of the jar some earth, or, better still, clumps of peat.

MECHANICAL LEECHES.—An effort has been made, without much success, however, to furnish an instrument for local depletion, resembling in its action that of the leech. The figure (563) illustrates the manner in which this instrument may be made.

It consists of a suction-tube (E) and an air-pump (A) connected by the screw B; C is a rod working air-tight through the cap of the suction-tube, and armed at its lower extremity with three sharp points (D) to puncture the skin.

Fig. 563.

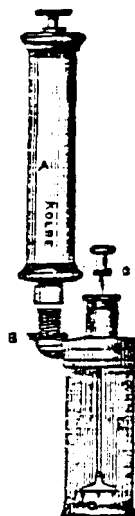

Koibe's mechanical leech.

ALEX PECK, ANTIQUÉ SCIENTIFICA

Fine Quality
Artifacts from
the History of
Medicine and Science

P.O. BOX 710
CHARLESTON, IL
61920 USA
217/348-1009

RECOLLECTION OF A SURGERY

The following several pages are from an interesting Civil War soldier's diary which ends with a note about the circumstances surrounding the resection of the right arm of the author.

The diary is that of John Northrop of the 103rd Ohio Vols., and it covers most of 1863. While campaigning around Knoxville, Tennessee, in late November, Northrop was shot by the enemy. As he writes, "...I was wounded severely in the right arm between the shoulder & elbow [at] about 3 o'clock in the afternoon. Went to the Bell House Hospital on Main Street, Knoxville. My arm was Resected. The bone taken out for the space of 4 inches. Very skillfully done by Dr. Coggsell of the 9th Army Corps."

The descriptive entry was made on 20 April 1864, some five months after the incident. It apparently took Northrop this long to recover well enough to write again and return to his diary. Having lost the use of his right hand, Northrop now must write left-handed. The change in handwriting is clear as one sees by comparing that of November 1863 to that of April 1864.

The doctor mentioned as performing the operation is Dr. George B. Coggsell, surgeon to the 29th Massachusetts Vols.

The diary is not signed, so internal evidence had to be used to identify the author. In addition, as fate would have it, I also have a muster roll of the 103rd, Co. C, dated October 1863. With the sample of Northrop's signature here and from various comments in the diary, John Northrop can be identified.

Most of the rest of the diary gives the typical routine of an enlisted man. One entry discusses a visit to a dentist, and Northrop's comments are not too different from that which could be made today..."Read some good books while waiting at the dentists..."

September 1764

Sept 20th 1764

Spent time at Wellington Ohio.
 Left off at 11:00 23rd
 18 & 3 on the way
 my being out on the
 skirmish line before
 the enemy at Knoxville
 last Jan. 24th 1764
 I was wounded severely
 in the right arm between my
 shoulder & elbow about
 3 o'clock in the afternoon
 went to the Belknap
 Hospital on main street
 Knoxville. My arm
 was dissected & the bone
 taken out for the space
 of 4 inches. My skill
 was done by Dr. Cogges-
 well of the 9th Army Corps.

First entry after being wounded.

~~Not to be written in the~~

Crow at my sisters
in Millington Lovell
County Ohio. It really
became a storm from my
room. Our first night.

The day has been very
pleasant and I have
enjoyed myself well
Tomorrow I am
twenty one years old.

Time flies away
my life seems but
a flash of time for.

Is it possible that
I shall be a man in
age in a few hours more.

God help me to improve
the present and learn
lessons from the
irretrievable past.

November, SUNDAY 22, 1863.

Camp near Knoxville

O how bright and
Beautiful this morning
clear and what a con-
trast I thought between
the morning and that of
the dark cloud of War that
hung over us. Can it be
that God the great ruler
of the Universe is watching
us and our Brothers who
are opposing us. May I
ask myself this question -
"Will not the Judge of all the
Earths do right!"

Removed our camp to day
to a hill adjoining the fort.

But when the fall light
of the moon we had to march
out and watch the enemy's

Last two entries prior to being wounded.

November, MONDAY 23, 1863.

Camp near Knoxville

All was quiet through the night and I repose sweetly on my couch of leaves. Day brought pleasantness.

Soon we were ordered to our camp again; at 11 A.M. fell in to line march up to the post and soon Gen. Haskell appeared. He spoke a few words to the troops assembled there. A horse (I think as the old flag (Union and stripes) was presented to the brass for the first time on the present Army for the Col. C. C. Cameron spoke the substance of both speeches. "We shall we dishonor the flag by surrendering it to the enemy." I say many feel sure our Country.

Frankfort Ky.

Weather lowery

Wrote two letters to day
one to Anel A. Northcutt,
The other to Sister
Matilda.

Fourteen Southerners de-
serted last night some
Cavalry have gone after
them to day.

How impatient some
are and how little they
love their Country

Obave me from
desertion.

My love of my Country
increases every day
My love to God is the
same.

January,

FRIDAY 23,

1863.

Went to the City
Had a ride to the City
Went to the dentist and
had our teeth filled costing
\$11.00 also two teeth extrac-
ted Had also a good Bath
costing 25 cts. Had some
good Books while waiting
at the dentist's and
then returned camp
at 4 o'clock. My gums
are quite sore from
the extraction of my teeth.

I feel every day more
and more the necessity
of living more fully and of
being more useful in
my every day life.

Companion helps me
to show my Collary

Compliments of Dr. Morgan

LAENNEC: THE GREAT INTERNIST

BY

JAMES DUDLEY MORGAN, A. B., M. D.

WASHINGTON, D. C.

THE STETHOSCOPE: A HISTORY

BY

DANIEL S. LAMB, A. M., M. D.

WASHINGTON, D. C.

Reprinted from WASHINGTON MEDICAL ANNALS, 1910

WASHINGTON, D. C.
BERKEFORD, PR., 605 F St., N. W.

1910

THE STETHOSCOPE : A HISTORY.*

By D. S. LAMB, A. M., M. D.,

Washington, D. C.

Stethoscopes may be classed in several ways. Those that are intended for use with but one ear, the monaural; those for use with both ears, the binaural or double; those for use by a number of persons at the same time, the polyaural. Some stethoscopes are rigid; all the earlier ones were; nearly all the later ones are flexible. Some of the earlier ones were made of rigid material but were jointed so that they could be bent.

* Read before the Medical Society, April 27, 1910, as part of the discussion of the paper on Laënnec by Dr. Morgan.

Some stethoscopes have two pectoral tubes, for listening to two regions at the same time—for instance, both the upper and lower lobes of a lung; these are called bipectoral or differential.

Most stethoscopes have a central tube; a few have been made solid throughout.

The pectoral opening nearly always has a flare like a trumpet, and usually is firm and unyielding; sometimes, however, it is made of soft rubber so that it may better adapt itself to curved surfaces. For this purpose Dr. T. G. Snelling, of New York City,* devised a rubber rim in 1867, to be applied to any ordinary stethoscope, and it has been much used.

The aural end is usually made small enough to fit into the concha of the ear; in the rigid instrument, however, the earpiece is usually made broad and has to be held against the ear by the hand.

Most of the earlier rigid instruments were made of wood or light metal, and many are still so made, but hard or soft rubber has for many years been generally preferred. Some rigid instruments are made in two parts that telescope one into the other or are screwed to each other.

Laënnec is credited with having been the inventor of the stethoscope. It is altogether probable, however, that before his time some one or more persons did pretty much what he did except that no record of the act was made.

He experimented with various substances, and concluded that glass and metal are too heavy; they interfered with the transmission of sound and are cold to the skin. He tried goldbeater's skin, tubulated and filled with air, and its shape retained by means of a central tube of pasteboard. He considered that the best material is paper, reed and wood, because they are of medium density. He therefore made and used a wooden cylinder, preferably of cedar, a foot long and $1\frac{1}{2}$ inches in diameter, with a central tube throughout three lines in diameter. He cut the cylinder in half to make it more portable; the two halves were screwed together. The pectoral end was hollowed out into a funnel shape $1\frac{1}{2}$ inches deep.

This instrument was used to examine the respiration; but to examine the beat of the heart an obturator was inserted in the excavation at the pectoral end, and was held in place by means

* *Med. Record*, 1870-1, V, p. 44.

of a copper tube that traversed the obturator and penetrated to some depth in the main piece.

Already by 1823 the stethoscope had been used also for other purposes: to examine the abdomen in pregnancy, in cases of fracture, in ascites, in tympanites, etc.

In the second edition of his book, 1826, he described a modification of the instrument. It was of the same length and diameter as the original, but instead of the two halves being screwed together the pectoral half ended above in a tenon $1\frac{1}{2}$ inch long, rounded off and covered with waxed thread or leather, and fitting into a corresponding mortice in the aural piece.

Laënnec was very particular about the dimensions of the instrument, and he also believed that the pectoral end should be slightly concave in order to adapt itself to the rounded shape of the body. He also made another instrument, of wood with thin walls, $1\frac{1}{2}$ inch in diameter, like a wooden cornet, with a haut-bois pavilion three inches in width at bottom and one inch in the upper diameter; he excavated the pectoral end in different ways, especially in a funnel shape. He believed that it was better to have a tubular than a solid instrument.

In 1828 P. A. Piorry, of Paris,* made a stethoscope with a *pleximeter* attachment. He believed that the Laënnec instrument was too bulky, that the bulk interfered with the conduction of sound. He therefore reduced the instrument both in length and thickness, but preserved the conoidal cavity at the pectoral end, regarding it as quite necessary. He made the instrument of light wood, like Laënnec preferring cedar, believing that this conducted sound better than any other wood. His illustration shows an instrument $7\frac{1}{2}$ inches long, diameter about half an inch in its upper two-thirds, and $1\frac{1}{2}$ inch in the pectoral end. The aural end was made of ivory and had a screw thread on it for fastening an aural cap that he called an operculum, because when not in use it was attached to the pectoral end. When in use the cap was fixed at right angles to the long axis of the instrument. The figure of this instrument shows an excavation at the pectoral end, with a screw thread both at the central opening and the inner under margin. At this end, also, an ivory pleximeter was screwed, and over this was the operculum. An additional cylinder of the same dimensions as the body of the stethoscope was

* De la percussion mediate, Paris, 1828, p. 327, plate I.

provided for use if desired, screwed to the main piece; also a conical obturator.

Delachambre* says that this instrument was adopted by the celebrated Louis and was the one most used up to at least the year 1883. The obturator was used in auscultation of the heart and great vessels.

Apparently the first FLEXIBLE tube of which we know was that of Nicholas P. Comins, an account of which was published in 1829.† He says that it was in use at the Royal Infirmary, Edinburgh. It consisted of two tubes, each seven inches long, $\frac{1}{2}$ inch diameter, except at the pectoral end, where the diameter of the opening was $1\frac{1}{2}$ inch. The two pieces were united by a perforated joint three inches long, placed at right angles to their ends, and fitting into the tubes in the same manner as the joints of a flute. This allowed the main limbs to form any required angle. The upper end of the instrument had a concave ear piece large enough to cover the ear, and by a movable joint could be placed in any necessary direction to the tube. All the joints were airtight.

The next mention of a flexible stethoscope seems to have been by a Dr. Stroud,‡ who began to use it about 1832. It consisted of rubber cloth lined with a spiral and elastic iron wire; the internal diameter was $\frac{1}{2}$ inch; it had a short, small aural end, of ebony, to insert into the ear; an ebony pectoral cup-shaped end; the entire instrument was 21 inches long. Stroud also devised a cardiscope, as he called it, which was a simple wooden stethoscope; and also a pleximeter.

In 1838 Dr. Francis Sibson, of Nottingham, England, began to use a flexible tube§ made by Thompson, an instrument maker of Nottingham; it consisted of two feet of ordinary elastic tubing, with a wooden, funnel-shaped pectoral end.

In 1840 Dr. Golding Bird, of London, described a stethoscope used by him,|| an ebony pectoral cup, one inch in diameter; flexible tube 16 to 20 inches long, of spiral iron wire, covered with silk or velvet, $\frac{1}{2}$ inch internal diameter; an ebony ball as ear piece on which was screwed an ivory plate two inches in diameter.

* Dict. Encyclop.

† *London Med. Gaz.*, 1829, IV, p. 427, figure; also, *Lancet*, London, 1828-9, II, p. 685.

‡ *Lond. Med. Gaz.*, 1841-2, I, p. 6, figure.

§ *London Med. Gaz.*, 1840-1, XXVIII, p. 912, figure.

|| *London Med. Gaz.*, 1840-1, XXVII, p. 442.



Laennec
1816



Piarry
about
1930
with pleximeter



Cammann
1852
Binaural



Cammann
solid



Snelling's soft
rubber rim
1867

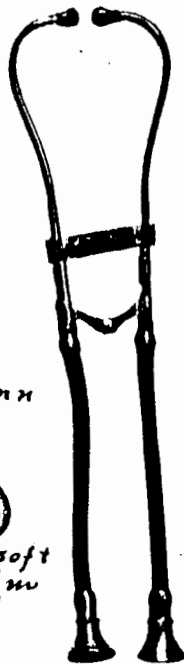

Allison
differential
1859



Baruch's
Bianchi's
Phonendoscope
1896

About 1843 Dr. C. J. B. Williams, of London, devised a BINAURAL stethoscope with a trumpet-shaped end; it consisted of two metal tubes attached to the pectoral part of an ordinary stethoscope, and there were flat ear pieces. It was, however, inflexible and awkward of application.

The two tubes of the binaural are usually let into a forked pectoral stem. Usually, also, they are made of metal in the aural part and of rubber in the part toward the forked stem; the rubber is usually silk covered. The tubes are held to each other in various ways; sometimes by a band of rubber or leather, by a metal joint, by a spiral spring, by a metal spring, etc. The forked stem may be of metal or hard rubber.

Comins, who in 1829 described a flexible stethoscope, also suggested a binaural, consisting of a tube connected at its middle at right angles to the cylinder that is applied to the chest and connected at its movable ends with two tubes movable on the same principle as for the two pectoral ends. It does not appear that the idea was practically applied. About 1851 a binaural devised by Dr. Arthur Leared, of London, was shown at the World's Fair, London, of that year. It had the chest piece, with two tubes and ear pieces.

In 1852 Dr. Geo. P. Cammann, of New York City,* devised an instrument consisting of a pectoral tube made of ebony, four inches long, with a trumpet-shaped opening at the chest end and globular piece at the other; into this piece were inserted two elastic aural tubes strengthened by wire. These tubes were each five inches long, and into them fitted two tubes of German silver seven inches long, each with an ivory-knob ear piece.

Many modifications of this instrument have been made. In some the metal and rubber tubes can be disjoined; in some others the metal tubes are held together by elastic ribbon, and in others by a hinged bar with a spiral spring.

There has been a great variety of binaural stethoscopes. A few only can be mentioned.

Dr. S. F. Speir, of Brooklyn, N. Y.,† devised a binaural with a chin rest, intended to intensify sounds produced by percussion. He called it an echoscope.

That by Mr. Irwin Palmer‡ has the tubes connected together

* *N. Y. Med. Times*, 1855, 1V, p. 140, figure.

† *Med. Record*, N. Y., 1871-2, VI, p. 175, Fig. 4.

‡ *London Med. Record*, 1881, 1X, p. 219, figure.

by a circular box-spring at the hinge; the dial plate attached to the hinge registered the divergence of the two metal arms, enabling diametric and other measurements to be made.

In the stethoscope of Dr. Chas. Denison, of Denver,* the tubes diminish in diameter toward the ear piece.

In that of Belcham-Keyes the tubes have an unusually large diameter, though gradually diminishing towards the ear piece; the metal plate connecting the rubber tubes has a toggle joint like that of the Bartlett instrument.

Dr. D. M. Cammann, of New York City,† modified the cup of Paul by placing it around the stethoscope tube instead of being separate from it. Cammann claimed that the bulb acted as a resonator, and stated that the idea of exhausting the air was suggested to him several years before by Dr. J. R. Leaming, of New York City.

Herschel, of London,‡ described and figured an instrument in which he substituted a clamp for the spring and loop, to hold the tubes together.

Dr. Mark I. Knapp, of New York City,§ devised a stethoscope in which the tubes were made of German silver covered with hard rubber, with an intervening tube made of German-silver wire covered with vulcanized rubber, or of soft rubber covered with silk or wool. A continuous equal caliber. Five years later|| he devised one in which the pectoral piece had a greater flare; and beyond the pectoral piece both tubes were of wired rubber tubing; the ear tips had soft rubber covers; the spring wire was to give firmness and spring.

Dr. S. A. Knopf, of New York City, devised two forms. One has wired rubber tubes, ear plates and tips, a steel head spring to hold the instrument against the ears; there is an oval chest piece for intercostal auscultation; a steel delineator or localizer, and a pleximeter and Flint percussion hammer.¶ This instrument was afterwards modified; the ear tips were discarded. The chest pieces were made of metal covered with vulcanized rubber. It also had a modification of Paul's suction cup.**

* *Med. Record*, N. Y., XXVII, 1885, p. 391, figure.

† *N. Y. Med. Jour.*, 1885, XLI, p. 27, figure.

‡ *Lancet*, 1891, I, p. 609.

§ *Med. Record*, 1895, XLVIII, p. 682, figure.

|| *Med. Record*, 1900, LVIII, p. 119, figure.

¶ *Med. Record*, N. Y., 1897, LI, p. 646, figure.

** *N. Y. Med. Monats.*, 1898, X, p. 79, figure; *Jour. Amer. Med. Assn.*, 1898, XXX, p. 27, figure.

Constantine Paul, of Paris, France,* devised a transfusion apparatus, part of which consisted of a round cupping glass; and he afterwards applied the idea to the stethoscope in order to make the instrument adhere to the skin of the patient examined, the air being exhausted by the rubber bulb.† A rim of soft rubber was afterwards added to the chest piece, so that the instrument could be more closely applied.‡

In some instruments the chest piece is quite short, as in that of E. T. A. Smith.‖ The stethoscope of Pickering, called

“Panarkes,” could be used as monaural, binaural and differential.§ It also had a percussor, hammer and pleximeter.

That of J. W. Cousins¶ could be used as monaural or binaural.

In 1859 Dr. S. S. Allison, of London,** devised a stethoscope with two aural and also two pectoral tubes, therefore a DIFFERENTIAL stethoscope; practically two single stethoscopes joined together.

R. D. Lyon†† devised a differential stethoscope of hard rubber, with a single stem and ear pieces.

W. H. Spencer‡‡ devised a flexible instrument with two ear pieces and two chest pieces.

In 1903 H. E. Wetherill, of Philadelphia,‡‡‡ described a differential of his own devising.

Paul§§ says that Marsh, of Cincinnati, invented two instruments; one was a flexible rubber stethoscope with a hemispherical obturator. The other was a guttapercha stethoscope, the aural plate of which was replaced by a “spout” having two rubber tubes perpendicular to the main tube; the pectoral piece could be replaced by another obturator having two rubber tubes, at the free end of each of which was a small pavilion. This was then a differential stethoscope, and was used by Marsh in his studies of Doctor Groux, who had the bifid sternum.

* *Maladies du Cœur*, Paris, 1883, p. 36. Figs. 9 and 10.

† See also *Bull. Acad. Med.*, Paris, 1881, X, p. 552.

‡ *Dict. Encyclop. des Scien. Med.*, Paris, 1883, XII, p. 58; Cammann, *Trans. Amer. Climat. Assn.*, May, 1885, p. 171; *N. Y. Med. Jour.*, 1886, XLIII, p. 405; etc.

‖ *Brit. Med. Jour.*, 1884, I, p. 309.

§ *Brit. Med. Jour.*, 1887, II, p. 1342.

¶ *Brit. Med. Jour.*

** Read before the Royal Society, Feb. 18, 1859; published in his “Physical Examination of the Chest,” London, 1861, pp. 325, 406.

†† *Duëlin Quart. Jour. Med. and Surg.*, 1862, XXXIII, p. 364, figure.

‡‡ *Brit. Med. Jour.*, 1874, I, p. 409, figure.

‡‡‡ *Amer. Jour. Med. Sci.*, 1903, CXXVI, p. 384.

§§ *Maladies du Cœur*, Paris, 1883, p. 47.

The PHONENDOSCOPE.—Apparently the beginning of the phonendoscope was in a binaural stethoscope devised by Dr. N. B. Marsh, of Cincinnati, in 1851. It was patented by him. Over the pectoral end of the instrument was stretched a membrane; two elastic tubes led from this to the ear. It is said that the ear pieces were inconvenient, and to use the instrument required both hands. It gave a muffled but loud sound caused by reverberation inside the instrument, due to the presence of the drum and the unequal diameter of the bore.

About 1869 Stern, of Vienna,* devised what he called a portable stethoscope; it consisted of a hollow conical tube, at the larger end of which was stretched a membranous diaphragm; the ear tubes opened separately into the hollow tube.

Yeates, of Dublin, about 1876† devised a hollow metal sphere with two rubber heads; this drum could be inflated through an opening guarded by a stopcock. There were two aural tubes, and several could be used.

Koenig‡ devised an instrument with a pavilion pectoral end and a rubber tube with ivory earpiece. The pectoral end had two rubber membranes forming a drum, with a stopcock by which the drum could be distended with air so that it would fit the surface of the body.

Sometime before 1892 a Dr. Fischer devised a flat ring with metal proximal and membranous distal covering and ear tubes.

The phonendoscope as it later appeared consisted of a heavy metallic cup with low margins, in which a light elastic hard-rubber diaphragm was made to vibrate both by sound waves and body movements. The instrument was made somewhat on the principle of the telephone. Two rubber disks may be used, and in some instruments to the middle of the outer disk is attached a rod ending in a small hard-rubber disk-shaped head. Two long rubber tubes with earpieces connect with the cavity of the instrument. It was devised by Aurelio Bianchi, of Florence, Italy, in 1894,§ and Eugenio Bazzi.¶

Bianchi's instrument was modified by Dr. H. B. Baruch, of

* *Wien Med. Presse*, 1869, X, pp. 778 and 802.

† *Med. Press and Circular*, Dublin, 1876, XXII, p. 58, figure.

‡ *Dict. Encyclop. des. Sci. Med.*, Paris, 1883, XII, p. 73, Figure 2.

§ *Policlinico Roma*, 1894, I.

¶ *Clinica Moderna*, Florence, 1895, I, p. 421, figure.

New York City, in 1896. The distal ends of the rubber tubes were attached to the ear pieces of an ordinary stethoscope.*

The phonendoscope claims some advantages over the stethoscope; the examination is quicker and more reliable, it can be used over clothing, and other sounds are excluded.

Dr. W. B. Outten, of St. Louis, Mo., patented, June 26, 1900, an instrument which contained several membranes, the principle the same; he called it an auscultator. Kohler's phonendoscope has only one rubber disk. Dr. R. C. M. Bowles, of Brookline, Mass., patented one June 25, 1901, the ear tubes of which were united at the place of insertion into a disk.

In 1841 H. Landouzy, of Paris,† had a POLYAUURAL stethoscope made of wooden tubes articulated, forty-eight inches long, and with many movable joints, so that it could be bent in many different directions, according to the positions of the patient and physicians, and with ten flexible appendages, so that as many persons could hear the sounds. He called it a stethopolygraph, or simply a polyscope. Andry‡ states that this polyscope was made of copper or tin, with a central tube; was 1½ inch in diameter, and was covered with thin tissue. Delachambre and Petit state§ that Landouzy made a wooden stethoscope with ten curved tubes. Because it was *too rigid* it was abandoned and a flexible one was made that was found practicable.

There have been but few stethoscopes altogether solid, that is, without any central tube. Cammann, who invented the binaural, also devised a short, solid instrument in two forms. The literature contains much discussion of the question as to which form is best, solid or hollow. Inasmuch as some solids and some liquids have been shown to transmit sound better than air it will be understood that there is something to be said in favor of the solid stethoscope.

Mention may be made again of stethoscopes with *percussion* attachments. That of Piorry has been already described. There have been others. That of Martin, which is at least thirty years old, consisted of a tube 6½ inches long, with funnel-shaped aural and pectoral ends; in the latter was an obturator; there was also

* *Med. Record*, N. Y., 1896, L, p. 624, Figs. 1 to 3.

† "Mémoire de l'Auscultation," Reims, Paris and London, 1841, p. 25.

‡ "De Percussion," etc., Paris, 1844, p. 120.

§ *Dict. Encyclop. des. Sci. Méd.*, Paris, 1883, 3d series, XII, p. 58.

a percussor, with a long stem extending through the obturator and tube, but readily removed; and a pleximeter with raised ends. The general plan may be said to be that of Piorry. All was made of hard rubber except the percussor.

The question of what is the best form of stethoscope is certainly of importance. For the examination of organs that differ in their characters of density and hollowness, and of gaseous or liquid contents and in other respects, and because different persons vary in their ability to recognize the qualities of sounds, it would seem to be altogether probable that the instrument would need to be different in different cases. Doubtless the question could be settled for any one individual by his trying several forms of stethoscope.

AMERICAN INSTITUTE OF THE HISTORY OF PHARMACY
Metropolitan Chapter
383 Route 46 West
Fairfield, New Jersey 07006
(201) 575-3507

March 2, 1989

Dr. M. Donald Blaufox
101 Drake Smith Lane
Rye, NY 10580

Dear Dr. Blaufox:

Here's good news for members of the AMERICAN INSTITUTE OF THE HISTORY OF PHARMACY, in the metropolitan New York/Philadelphia/Connecticut area. You've shown such interest in the work of the Institute, that we have established a Metropolitan Chapter.

Daniel Glassman, President of DANIEL GLASSMAN ADVERTISING of Fairfield, New Jersey, has been appointed President of the new chapter. Mr. Glassman has taken a keen interest in the history of Pharmacy since he graduated from the School of Pharmacy of COLUMBIA UNIVERSITY in 1963. At the present time, the Reception Area of his advertising agency bears the decor of an old-fashioned drug store - a fact that has gained much interest and commendation in the health care field.

Members of the Institute who live in the New York/Philadelphia/Connecticut area will now have an opportunity to meet on a regular basis and discuss the facts and folklore of the History of Pharmacy.

Plan now to attend these meetings, where you may be discussing such topics as the apocathary inspectors in Spain in the 12th century or the Philadelphia drug store that during the War of 1812 stocked over 300 items - all the way from Acacia to Virginia Snakeroot.

The other officers of the metropolitan chapter are: Mr. John Baruch (President of REED & CARNRICK), Vice President; Mr. Stephen Gross (Dean, LONG ISLAND UNIVERSITY - Arnold & Marie Schwartz College of Pharmacy), Secretary; and Mr. Donald Mueller (President, WELKIND REHABILITATION HOSPITAL), Treasurer.

For complete details about the work of the Metropolitan Chapter and membership within the organization, contact Daniel Glassman at DANIEL GLASSMAN ADVERTISING, One Gothic Plaza, Fairfield, New Jersey 07006 or call (201) 575-3507.

Sincerely,

Daniel Glassman, President
A.I.H.P. Metro Chapter

DG: bz

THE REVITALIZER

Professional

Massage Therapy System

Relax aching, cramped muscles... stimulate circulation... relieve tension due to stress... reduce fatigue... ease soreness... **REWARD YOURSELF** with this remarkable health massager.

This *professional* health massager works on special built-in frequencies and pulsations from the rugged, specially-designed motor, to create a high-frequency oscillating action that reaches deep down to relieve sore, aching muscles. The gentle, soothing action of the twin-speed motor is easy on the skin while penetrating deep to therapeutically relax muscles... stimulating circulation.

Whether you are suffering from over-exertion, fatigue, stress, stiffness, strain or tension, you'll find amazing benefits with the world's best-designed massager. To help you reach the hurt and reduce the ache, the lightweight, compact construction of the REVITALIZER is designed for simple one-hand operation that allows you to use it easily in any position... sitting, standing or reclining. And you can use it anywhere—at home, the office, when traveling—anywhere there is a power source. It stores easily, too!

Used by health professionals in hospitals, clinics and doctors' offices, the REVITALIZER is recommended as a therapeutic physical aid that provides effective massage on the scalp, feet, face, neck, thighs, shoulders, calves, upper and lower back, buttocks, hips, chest and stomach.

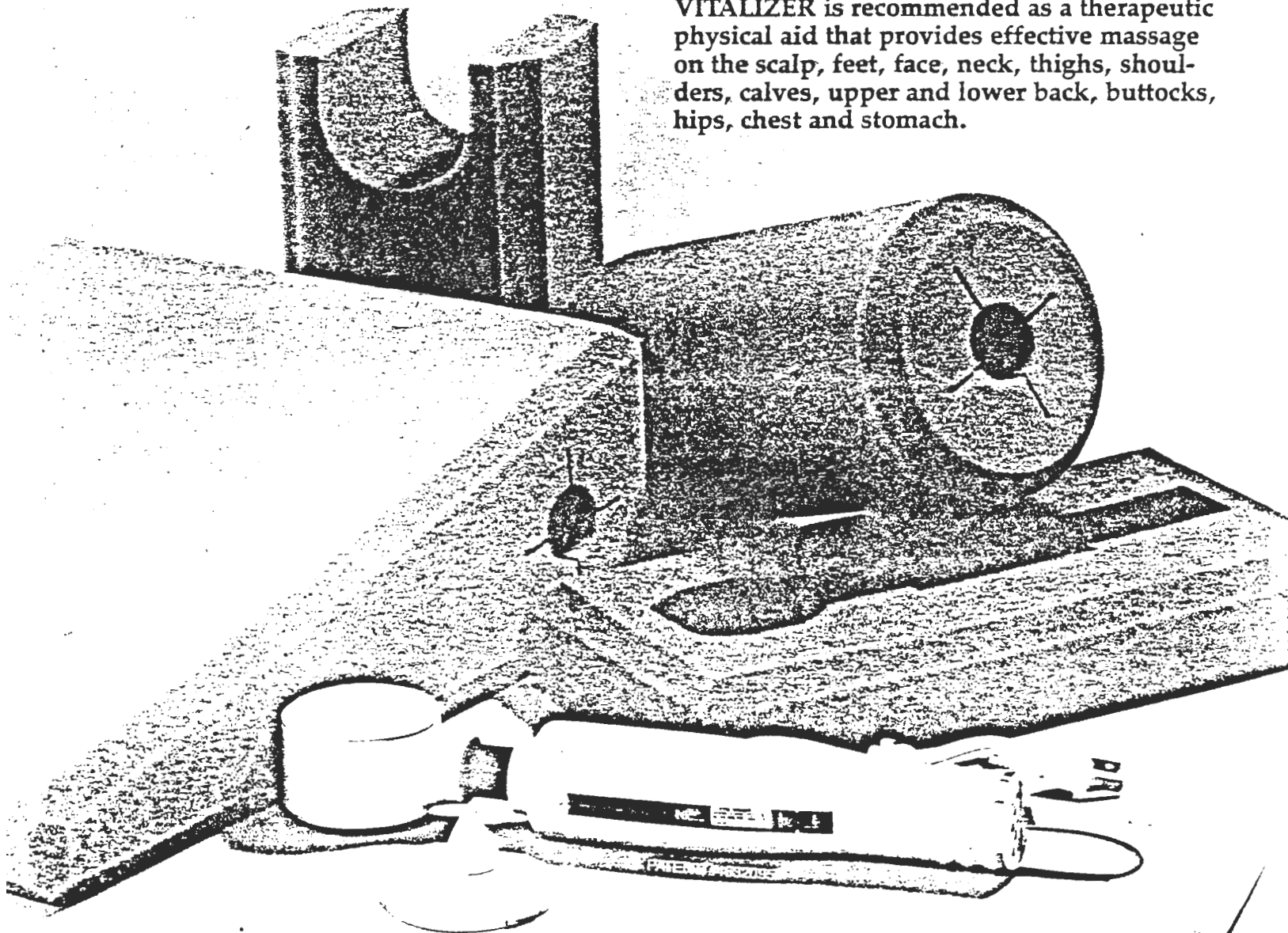

THE VARIETY OF ACCESSORIES FOR THE ENTIRE BODY

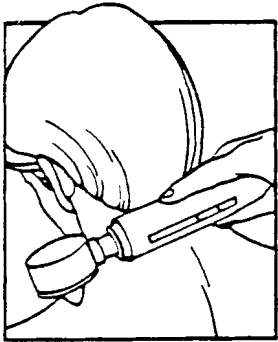

Neck & Scalp



Face

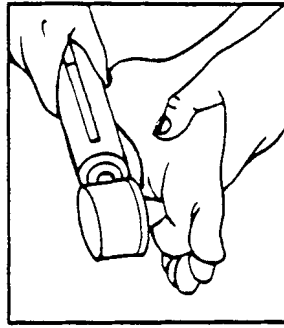

Foot

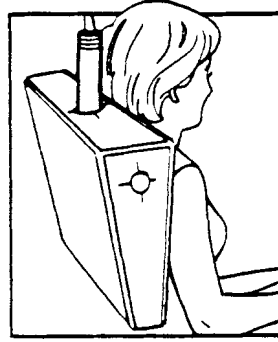

Back & Neck

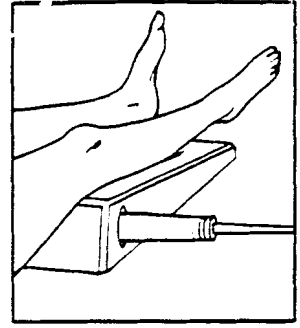

Behind the Knees



Hip

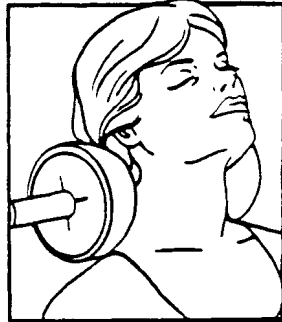

Neck & Shoulder

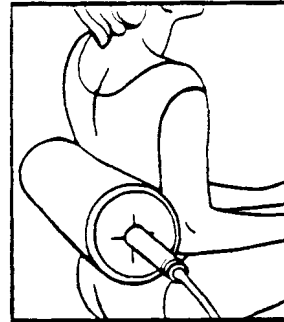

Lower Back

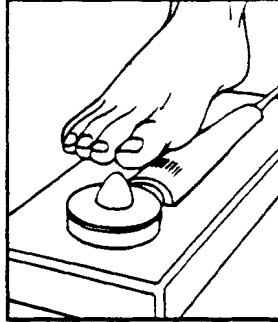

Foot

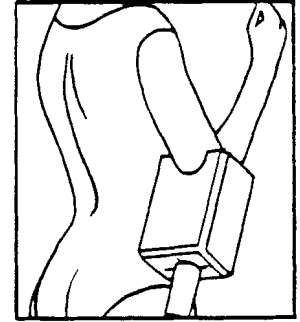

Elbow & Knee Joints

ATTACHMENTS

The polyurethane attachments pictured here and described in our instruction booklet are versatile accessories that allow you to apply the power of the Massager in a variety of positions over the entire body to achieve the maximum effectiveness and benefits of this therapeutic massager.

THE WEDGE turns any chair into a *massage chair!* Simply place the Massager in either the top or the side of the Wedge for an invigorating back, leg or shoulder massage.

THE ROUND PILLOW's innovative cylindrical surface helps concentrate penetration to localized areas being worked on, including the neck, shoulders, lower back, bottom of feet or behind the knees.

THE FOOT PAD is an easy-to-use aid for tired, aching feet. For best results, place your foot directly on top of the Massager. This application of the oscillating action effectively stimulates the reflex points on the bottoms of your feet, while releasing tension.

THE U-PILLOW makes it easy and efficient to relax muscles in the neck, shoulders, thighs, and joints.

The REVITALIZER

"The preventive way ten minutes a day for your health."

COMPLETE SYSTEM \$269.95

YOU WON'T FIND THIS QUALITY SYSTEM IN ANY STORE.

Available only from

THE TAMIKO CORPORATION

15020 Delano St., Van Nuys, CA 91411

(818) 782-7720 Cal. res. call (800) 221-4687

Outside Cal. call (800) 222-4687

Salon

16161 Ventura Blvd., #103, Encino, CA 91436

(818) 783-7221

MAIL ORDER COUPON

Please send me the following

QTY.	ITEM	PRICE	AMOUNT
	Set(s) massager, wedge, round pillow, U-pillow, foot pad & acupressure attachment	\$269.95	
	Massager(s) only	\$209.95	
	Polyurethane Wedge(s)	\$ 15.00	
	Polyurethane Round Pillow(s)	\$ 10.00	
	Polyurethane U-Attachment(s)	\$ 10.00	
	Polyurethane Foot Pad(s)	\$ 5.00	
	Acupressure Attachment(s)	\$ 20.00	
	PLUS Shipping Charge, per unit ordered	\$ 4.00	
	Calif. residents add sales tax		TOTAL

Name Phone

Address

City State Zip

Check MasterCard/VISA
 American Express Carte Blanche/Diners
 Money Order Discovercard

Card Number Expiration Date

Representative