

MEDICAL



COLLECTORS



ASSOCIATION

NEWSLETTER NO. 9
March 1987

Dear Colleagues:

Response to the call for renewal of membership has been impressive. More than 90% of last year's members have already renewed. As is our policy from previous years, I will not be sending this Newsletter to anyone who has not renewed his or her membership at this time, therefore, if any of you know of colleagues who have been a little lazy, please remind them that there will be no further notices for renewal of membership in the association.

Plans are proceeding very nicely for the second annual meeting which will be held at the New York Academy of Medicine. We now have approximately fifty persons signed up for attendance at the meeting itself and about sixteen people have signed up for the Chinese banquet, which will be held that evening. Yolo Coffeen has been organizing the dealers' session and she expects that about 10-12 dealers will be exhibiting following the morning lecture session. The Academy has been kind enough to allow us to use one of their meeting rooms for the dealers session. Present plans call for the morning lectures to be followed by a break of about an hour and then an open dealer sales session. Mr. Brett Kirkpatrick, the Librarian for the Academy, is mounting an exhibition of the medical antique collection of Dr. "Stretch" Becker, which was donated from his estate by his wife to the Academy. He plans to have this collection on display at the time of our meeting. I have not seen it yet myself, but I understand that it is an extremely attractive grouping of medical antiquities.

I have not received any input concerning the meeting at Chapel Hill to be under the sponsorship of Dr. Larry Vincent. If anyone has any information about dates or any other pertinent facts, please let me know. After the meeting in May, I will finalize the dates of the next meeting with Dr. Vincent and we will plan to proceed. Although I cannot announce a definite date at this time, I can announce that in 1988 the Medical Collectors meeting will be held at Chapel Hill.

Following the Newsletter and usual preface material, contained in this issue is a photocopy of a letter from Roger G. Kennedy, Director of the National Museum of American History, thanking the Association for its donation to the collection. This donation was the result of a surplus generated from the Medical Collectors meeting last year. Also enclosed in this issue is a photograph of the item which was purchased with these funds. I hope that the meeting at the Academy will similarly yield enough of a surplus to present a significant donation to their rare book room. These donations are in lieu of being charged a meeting place fee by the host organization.

Also with respect to meetings, please note the enclosed announcement about the second International Scientific and Medical Instrument Fair, which promises to

Founder: M. Donald Blaufox, M.D., Ph.D.

Mailing Address : M. Donald Blaufox, M.D., Ph.D. • 1300 Morris Park Avenue • Bronx, New York 10461 • (212) 904-4011

be a most exciting event. I understand that the first fair was extremely successful and they currently are planning two per year.

This issue of the Newsletter owes its authorship to a significant number of contributors. I hope that this is the beginning of a meaningful trend. Dr. Paul S. Musco has sent in an item for the "CAN YOU IDENTIFY THIS" column. Any guesses are gratefully welcome. Please send your comments directly to me for distribution in the next Newsletter. I have not received any new comments for that column or submissions. It would seem to me that a lot of you must have things of unknown origin and that this could serve a useful purpose if we could mount a significant amount of responsiveness among the membership.

Once again, we have a contribution which is taken from PHARMACY IN HISTORY and kindly supplied to us by Dr. William Helfand. The photocopy describing Dr. Graden's improved compound inhaler is taken from my own collection of medical ephemera.

Mr. Alex Peck has taken a little rest from his supply of interesting articles to the Newsletter and in this issue, instead, has supplied us with some photographs and the original patent of a most interesting and unusual thermometer.

Dr. Audrey Davis has been kind enough to supply us with a most informative and interesting article on bloodletting in Ophthalmology. Perhaps it would be more appropriate to include a patent of a bleeding device with her article; I have a most unusual bleeding device, however, have not yet received the patent copy for which I applied. It will be in the next issue so we'll have to settle for a temperature measuring device instead. Its interesting that Dr. Davis writes about the role of Dr. Heurteloup in bloodletting and supplies us with a photograph of his most unusual device, which happens to be the device which was acquired for the Museum of American History with the use of Medical Collectors Association funds. I thought that the membership would be interested in another and extremely productive portion of Baron Heurteloup's endeavors, namely, Lithotripsy. Following Dr. Davis' article, I have included a photocopy of the title page of a monograph by Dr. Heurteloup which is in my possession, along with a photocopy of his Lithotripter.

As usual, we have included another portion of Dr. Pengelley's ongoing narrative of medical museums. For those of you who did not take notice in the last Newsletter, let me remind you that Professor Pengelley's entire monograph on medical museums, "A Travelers Guide to the History of Biology and Medicine" is available from: The Trevor Hill Press, P.O. Box 1851, Davis, California 95617-1851 USA.

Finally, Dr. Irwin Berman, with the kind cooperation of the C.B. Fleet Company, has allowed me to enclose with this Newsletter, a most interesting brochure on the history of the enema which was written by him and published by Fleet. This is an extremely interesting account which shows the tremendous variety, complexity and interest that can be related to a device which many of us may regard as mundane. The examples from Dr. Berman's collection certainly are very fine examples of the wide variety of early medical instrumentation.

Also enclosed with this Newsletter is an announcement of the Museum of Ophthalmology in San Francisco, and of a couple of new books which are being offered to collectors by Barry Wiedenkiller.

Once again, if any of you have any material of interest to the membership please send them to me. The next Newsletter will be published sometime during the summer.

Sincerely,
M. Donald Blaufox, M.D., Ph.D.

NATIONAL MUSEUM OF AMERICAN HISTORY

SCIENCE, TECHNOLOGY, AND CULTURE

February 5, 1987

Dr. Donald Blafox
Medical Collectors Association
Mazer Building, Room 324
1300 Morris Park Avenue
Bronx, New York 10461

Dear Dr. Blafox:

Thank you very much for the check for \$690.37 given on behalf of the Medical Collectors Association after its first meeting held in Washington, D.C. at the NMAH in April 1986. These funds are much appreciated. The money shall be used to augment the medical collections and will enable the Division of Medical Sciences to acquire objects which it might not have had the means to purchase.

We are grateful for your kindness in this donation and wish the organization well in an endeavor of mutual interest to the Smithsonian Institution.

Sincerely,

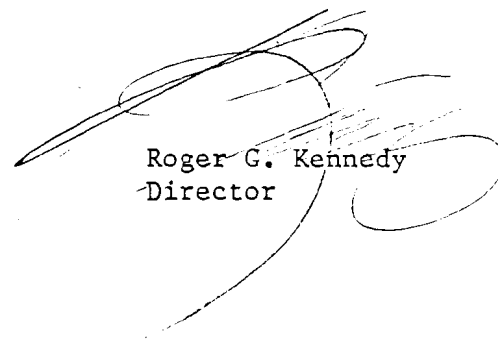

Roger G. Kennedy
Director

THE SECOND INTERNATIONAL SCIENTIFIC & MEDICAL INSTRUMENT FAIR

The Gloucester Hotel
Harrington Gardens, London SW7.

Sunday, 5 April 1987

10:00 to 17:00 Admission £1.50

After the astonishing success of the first fair we are moving to a larger and more prestigious venue. If you would like further details, or wish to exhibit, please contact the Organiser:

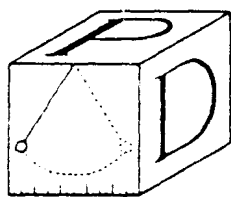

Peter Delehar Marketing
146 Portobello Road,
London W11 2DZ.
Tel. 01-866 8659

CAN YOU IDENTIFY THIS

Material: 9.5 cm long, disc mounted on threads.
Ivory and metal.
Maker: Elliot Bros., 449 Strand, London, London
Presumed Use: Optical
Date: Unknown

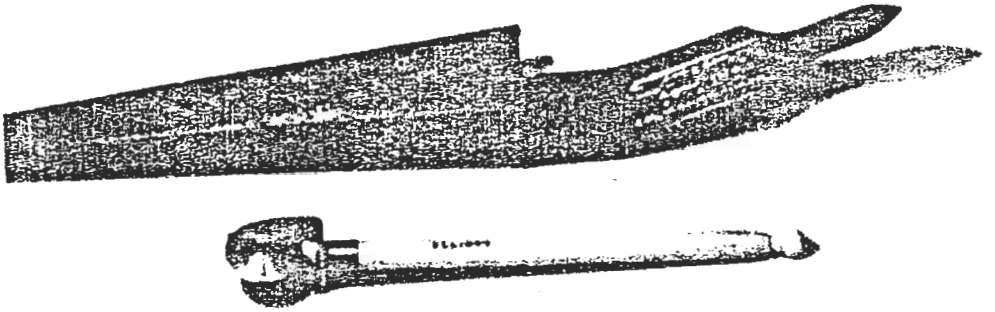

I think this is a:

From:

Please return to M. Donald Blaufox, M.D., Ph.D.

Historical Images of the Drug Market—I



by William H. Helfand

In the illustration for an advertisement for Antipon, a product to be used in the treatment of obesity, the manufacturer has given a realistic view of a proper British pharmacy at the end of the 19th century. The pharmacist himself extols the virtues of Antipon, a product purported (as the text indicates) to effect a reduction of between 8 ounces and 3 pounds in the first 24 hours. The problem Antipon was designed to treat is still with us today, even though the product itself has long disappeared. This piece of publicity appeared as an insert—a popular medium for advertising in journals, theatre programs, books, etc.—in which the advertiser usually had two, four, or eight pages in which to provide information on the products being promoted. (Original of illustration, 17 x 12.5 cm., is in the William H. Helfand Collection).

THE DISCOVERY OF A LIFETIME. GREAT EVENT FOR FAT PEOPLE.

When a fat person "discovers" Antipon, after having tried with no success all the old-time methods of weight-reduction, it is a great event for him or her. It is the discovery of a lifetime, for it is the true cure for the disease of obesity—a disease fraught with many dangers, and a prolific source of other diseases.

It was a great event for fat people in general when Antipon was first offered to the world after some years of arduous, scientific researches and experiments, for it was the realisation of the dreams of generations of medical men who vainly sought a permanent cure for obesity, and yet would not depart from the old errors of starvation, sweating, and mineral drugging.

Antipon has done away with all these abuses—at least, they are gradually disappearing in the light of Antipon's growing fame.

Antipon feeds the subject, not starves him; prescribes him gentle fresh-air exercise and rest, not fatigues him with gymnastics and sweating; tolerates no mineral or other dangerous drugs; but gives him a few doses daily of a harmless vegetable preparation which he enjoys without fear of uncomfortable after-effects. That is practically the entire treatment. There are no unpleasant food restrictions. Antipon, we may say, compels the subject to eat heartily, for it has a most wholesome, tonic effect on the alimentary system,

renewing appetite and promoting perfect digestion.

The re-strengthening element of the treatment is no less remarkable than the re-beautifying element. Antipon possesses the power not only of eliminating all the superfluous fatty matter, but of destroying

the unnatural tendency to fat development in excess of the physical needs and welfare of the organism. Hence the overwhelming superiority of Antipon as a cure for the disease of obesity.

The reduction of between 8 oz. and 3 lb. in the first twenty-four hours is an augury of a rapid return to beauty of form and normal weight. Each day's decrease is a delightful step towards health and symmetry. Then, again, the removal of the clogging masses of superfluous internal fatty matter that hamper the vital machinery is

a work which Antipon performs well, with lasting benefit to the general health.

The "discovery" of Antipon has undoubtedly lengthened the span of years of thousands, for healthy old age is absolutely impossible with the obese. Try Antipon now; there is no time like the present.

Antipon is sold in bottles, price 2s. 6d. and 4s. 6d., by Chemists, Stores, etc. or, in the event of difficulty, may be had (on remitting amount), carriage paid, privately packed, direct from the Antipon Company, Olmar Street, London, S. E.



IN THE CHEMIST'S SHOP.

CHEMIST (to Stout Lady): "I can positively assure you, madam, that Antipon will permanently reduce your weight to normal."

Dr. Graydon's Improved Compound Inhaler.

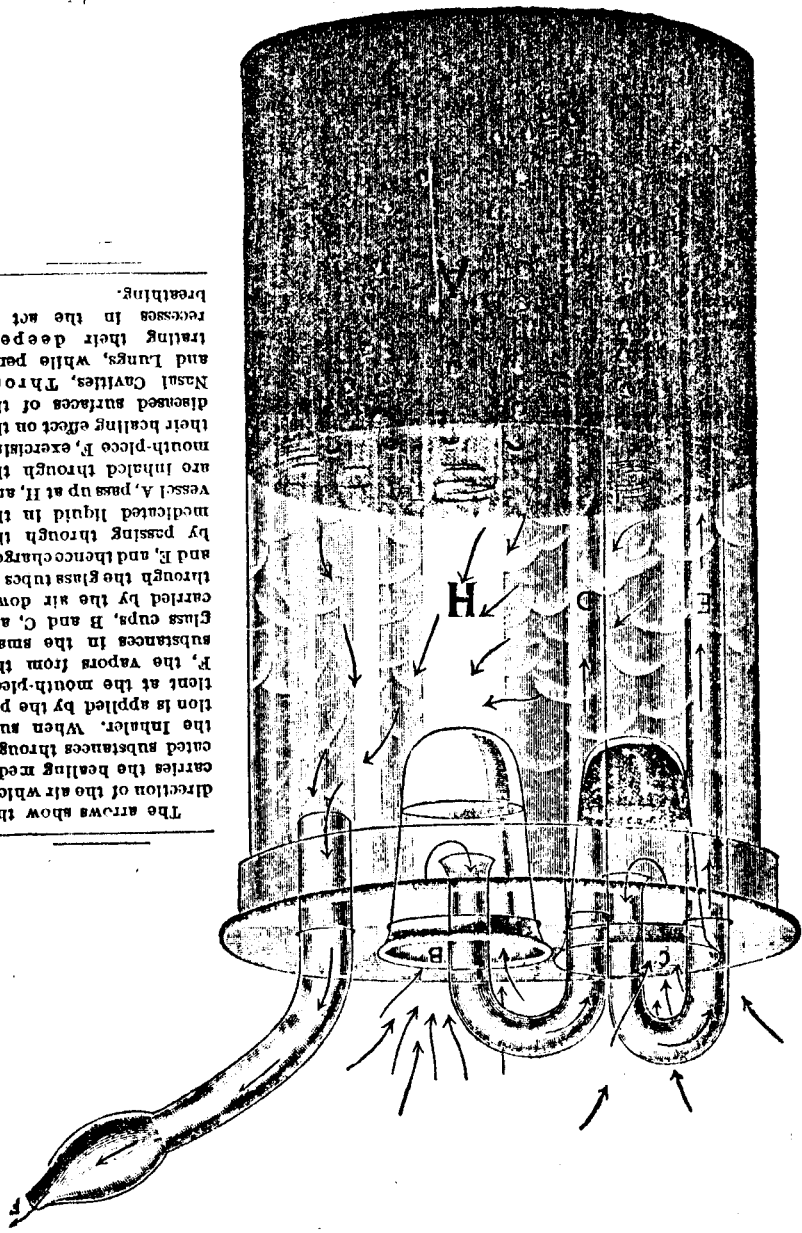

The arrows show the direction of the air which carries the healing medicated substances through the Inhaler. When suction is applied by the patient at the mouth-piece F, the vapors from the small glass cups, B and C, are carried by the air down through the glass tubes B and F, and thence charged by passing through the medicated liquid in the vessel A, pass up at H, and are inhaled through the mouth-piece F, exerting their healing effect on the diseased surfaces of the Lungs, while penetrating their deepest recesses in the act of breathing.

FOR MEDICAL INHALATION TO THE NOSE, THROAT AND LUNGS.

The Heart, Lungs and Kidneys.

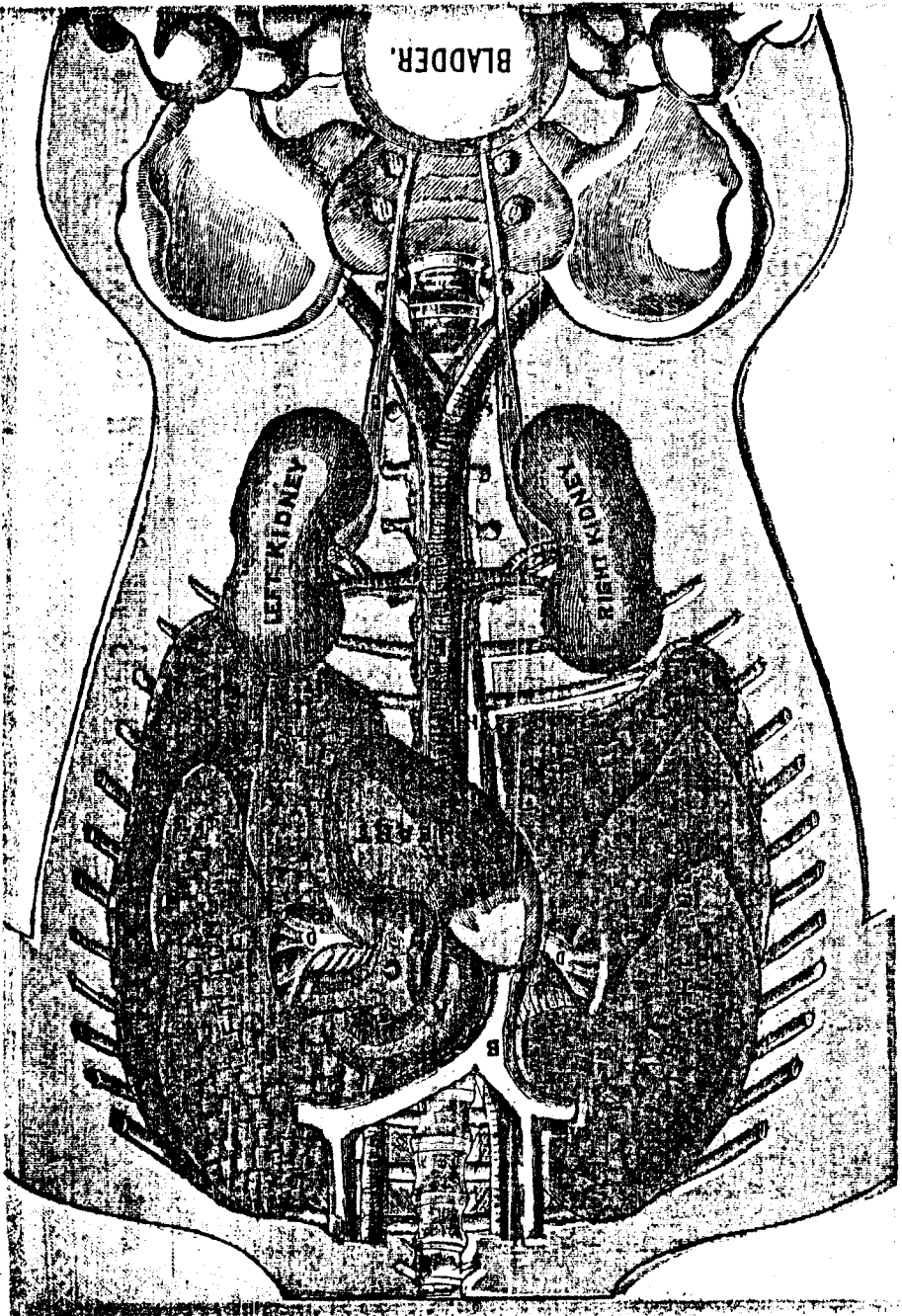

DIAGRAM OF THE HEART, LUNGS AND KIDNEYS, SHOWING THE CLOSE RELATIONS BETWEEN THESE THREE GREAT ORGANS, WHICH CIRCULATE AND PUMP THE BLOOD. [The stomach, liver, and other organs are omitted to make the above illustration clear.]

ALEX PECK, ANTIQUÉ SCIENTIFICA

Fine Quality
Artifacts from
the History of
Medicine and Science

P.O. BOX 710
CHARLESTON, IL
61920 USA
217/348-1009

20 February 1987

Dear Dr. Blaufox:

Enclosed is a photograph of a rare clinical thermometer known as Immisch's Avitreous Thermometer. It was patented in England in 1881/1882 by Moritz Immisch, and appears in medical supply catalogues of the period. I gather that its use met with limited success as by 1900 I do not find it mentioned for sale and as so few examples are available today.

Here are copies of Immisch's provisional specification, A.D. 1881, 6th July, No. 2953, and the final specification approved 4 January 1882. The diagrams are slightly larger than true size.

The example I show is in good working order and is serial number 5920. The case tests to 15K gold, though unmarked, and is the size you see in the advertisement from a Traux, Chicago, catalogue of c. 1886. Note that Traux lists the price of the Immisch in a gold plated case at \$25. The claim **WILL LAST A LIFETIME** should probably be amended to **OR AS LONG AS ONE WOULD WANT TO USE IT**, bearing in mind its apparent lack of popularity.

I hope that this makes a good addition to the fine **MCA Newsletter**.

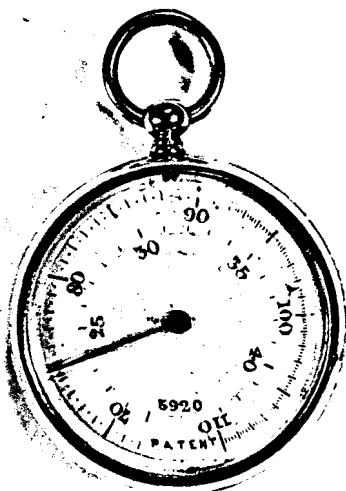

Best regards,

Alex Peck
H



WILL LAST A LIFETIME!

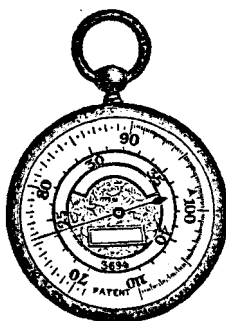

[Exact Size.]

—IMMISCH'S—

Avitreous Clinical Thermometer IN SILVER OR GOLD.

AWARDED THREE SILVER MEDALS, 1885.

THE BEST THERMOMETER IN THE WORLD.

Easy to read and easy to use, but not easy to break. Will never vary with age, like the glass thermometer.

Absolutely correct, and guaranteed to the fraction of a degree by Kew Observatory Certificates.

Perfectly constructed for either surface or internal application. Already used by thousands of physicians in Europe.

I have used Immisch's Avitreous Clinical Thermometer for the past two months, and found it to be accurate and very convenient to use.—From a recent lecture by FRED'K R. S. DRAKE, M.D., Clinical Prof. Practice of Medicine, Medical Department University of the City of New York.

—SOLD BY—

Messrs. CHAS. TRUAX & CO., Chicago,
And All Instrument Houses.

For Prices, see page 334.

At Wholesale by SARDY, COLES & CO., Owners of U. S. Patent,
96 & 98 Maiden Lane, New York.

In writing them please mention this list.

~~~~~  
A.D. 1881, 6th JULY. N° 2953.  
~~~~~

Thermometer.

LETTERS PATENT to Moritz Immisch, of Highgate Road, in the County of Middlesex, for an Invention of "AN IMPROVED THERMOMETER."

PROVISIONAL SPECIFICATION left by the said Moritz Immisch at the Office of the Commissioners of Patents on the 6th July 1881.

MORITZ IMMISCH, of Highgate Road, in the County of Middlesex. "AN IMPROVED THERMOMETER."

- 5 My Invention relates especially to thermometers to be used for clinical purposes where smallness and handiness are requisite, and it consists essentially in the employment of a volute tube acting on the Bourdon principle, which tube is caused to give motion to a pointer or hand by being filled with a highly expansive fluid, such as ether or alcohol, expanding in heat and contracting in cold.
- 10 The tube has a suitable number of turns, and may be fixed either at its inner or at its outer end. When the tube is fixed at its inner end, the outer or free end acts upon a rack which gears with a pinion, the spindle of which carries the pointer or hand. By way of connecting the extremity of the tube with the rack, the former is provided with a pivot corresponding to a jewel hole fitted to the end of a flat spring which is screwed on the face of the rack. The flat spring has slots cut into it, so as to allow it to be shifted for the purpose of adjusting the motion of the rack. The axis of the rack carries a weight or counterpoise, which serves to properly poise the system in the vertical positions. The centre pinion carrying the hand or pointer is fitted with a hair spring, which serves, in the first place, to keep
- 20 the teeth of the pinion well against those of the rack; and secondly, as its force is opposed to the action of the tube, it serves to effect the final adjustment.
- When the outer end of the volute tube is fixed, an intermediate rack is employed, against the side of which the free or inner end of the tube abuts, either simply by means of an upright pin, or by means of a pivot and hole. This rack communicates
- 25 its motion to a pinion fitted to a second rack gearing with the centre pinion carrying the indicating hand or pointer. A counterpoise on the rack and a hair spring on the centre pinion are provided, as in the first arrangement.

Immisch's Improved Thermometer.

The whole of the mechanism is enclosed in a suitable metal case provided with a suitably divided face, and covered with a glass or crystal.

In some cases the volute tube may be exhausted of air and hermetically sealed, and the surrounding space of the case, which latter is rendered air-tight, may be filled with a highly expansive and heat absorbing vapour, which being acted upon 5 by heat would expand and compress the tube, the mechanical arrangements being similar to those above described. In this case the instrument would be specially adapted for surface temperatures, and the enclosing case would be partly of silver and partly of a non-conducting material.

In each case means are provided by which the hand or pointer may be fixed 10 after a temperature has been taken or registered.

The bow or handle of the instrument is made movable, permitting a motion of a quarter of a turn. The pivot of the stem reaches into the inside of the case and carries an eccentric, against the circumference of which rests a spring fixed to the bottom surface of the plate carrying the whole mechanism. This spring is fitted 15 with a jewel end stone, upon which the spindle of the centre pinion carrying the indicating hand or pointer runs. When the bow or handle is turned upright the eccentric permits the spring to rise, in doing which it lifts the pinion and presses its face against the face of the bracket in which the top end of the spindle revolves. The friction thus produced resists the motion of the tube and fixes the indicating 20 hand or pointer. On turning the bow or handle back a quarter of a turn, the eccentric forces the spring downwards and the pinion is instantly released.

The stopping of the hand or pointer may also by any simple contrivance be varied so as to take place laterally instead of longitudinally by an arm or spring, or arms or springs, pressing against a disc fixed for that purpose on the centre pinion 25 spindle.

The bow is split so as to allow a long handle to be introduced and screwed into the stem if required.

Immisch's Improved Thermometer.

SPECIFICATION in pursuance of the conditions of the Letters Patent filed by the said Moritz Immisch in the Great Seal Patent Office on the 4th January 1882.

MORITZ IMMISCH, of Highgate Road, in the County of Middlesex. "AN
5 IMPROVED THERMOMETER."

My Invention relates especially to thermometers to be used for clinical purposes where smallness and handiness are requisite, and it consists essentially in the employment of a volute tube acting on the Bourdon principle, which tube is filled with a highly expansive fluid, such as ether or alcohol, and by expanding in heat
10 and contracting in cold is caused to give motion to a hand or pointer.

The tube is surrounded by two upright strips of metal soldered or otherwise fastened to the bottom of the case which encloses the whole. These two upright strips thus form an open box within which the tube works and serves, in the first place, to prevent the tube being bent by a violent shock; and secondly, to increase
15 the heating surface, thus rendering the instrument more sensitive.

The tube has a suitable number of turns and may be fixed either at its inner or at its outer end. When the tube is fixed at its inner end, the outer or free end acts upon a rack which gears with a pinion, the spindle of which carries the pointer or hand. By way of connecting the extremity of the tube with the rack
20 the former is provided with a pivot working in a hole, drilled in the outer extremity of the rack at a suitable distance from the fulcrum of the same. The spindle of the centre pinion carrying the hand or pointer is fitted with a hair spring, which serves, in the first place, to keep the teeth of the pinion well against those of the rack; and secondly, as its force is opposed to the action of the tube it
25 serves to effect the final adjustment.

When the outer end of the tube is fixed, an intermediate rack may be employed, against the side of which the free or inner end of the tube abuts, either simply by means of an upright pin or by means of a pivot and hole. This rack communicates
30 its motion to a pinion fitted to a second rack gearing with the centre pinion carrying the indicating hand or pointer. A hair spring on the spindle of the centre pinion is provided as in the first arrangement.

The whole of the mechanism is enclosed in a suitable metal case provided with a suitably divided face and covered with a glass or crystal. The tube and the inside of the case is covered by a film of a highly absorbent substance, such as
35 gum or alum, which covering assists radiation and renders the action of the instrument more prompt.

In some cases the volute tube may be exhausted of air and hermetically sealed, and the surrounding space of the case, which latter is rendered air-tight, may be filled with a highly expansive and heat absorbing vapour, which being acted upon
40 by heat would expand and compress the tube; or the condition of things may be reversed by filling the tube with the vapour and rendering the surrounding space void of air. This plan is preferable for instruments intended to register surface temperatures. The mechanism is fixed on a silver plate which is the part coming
45 in contact with the surface to be examined, and the rest of the case may be made of a non-conducting material in order to neutralize or minimize the effect of the varying temperature of the atmosphere. This end may also be gained where the whole of the case is made of metal, by covering the tube and the inside of the open box referred to above by a highly absorbent substance, such as gum or alum, and leaving the outside of the box and the rest of the case brightly polished. The
50 mechanical arrangements are similar to those above described.

Means may be provided by which the hand or pointer may be fixed after a temperature has been taken.

The bow or handle of the instrument is made movable, permitting a motion of

Immisch's Improved Thermometer.

a quarter of a turn. The pivot of the stem reaches into the inside of the case and carries an eccentric, against the circumference of which rests a spring fixed to the bottom surface of the plate carrying the whole mechanism. This spring is fitted with a jewel end stone upon which the spindle of the centre pinion carrying the indicating hand or pointer runs. When the bow or handle is turned upright the eccentric permits the spring to rise, in doing which it lifts the pinion and presses its face against the face of the bracket in which the top end of the spindle revolves. The friction thus produced resists the motion of the tube and fixes the indicating hand or pointer. On turning the bow or handle back a quarter of a turn, the eccentric forces the spring downwards and the pinion is instantly released.

The stopping of the hand or pointer may also by any simple contrivance be varied so as to take place laterally instead of longitudinally, by an arm or spring, or arms or springs, pressing against a disc fixed for that purpose on the centre pinion spindle.

The bow is split so as to allow a long handle to be introduced and screwed into the stem if required.

The instrument may be rendered self registering by fitting a ratchet wheel with very fine teeth to the spindle of the centre pinion. A pawl or click pressed lightly against the wheel by a hair spring prevents the hand from going back till the wheel is released by lifting the click, which may be done by means of a push piece or other suitable means.

With self registering instruments it is advisable to make the outer extremity of the rack movably connected with the tube, in such a manner that ordinarily it would be held in its place by a spiral spring fitted to the spindle of the rack, the movable piece abutting against a pin fixed in the body of the rack. When the temperature has attained its greatest height, the pawl or click prevents the centre pinion moving back, but the tube in receding carries the movable piece with it and on releasing the ratchet wheel the spiral spring forces the hand to its proper position. By means of this arrangement the pressure against the pawl or click can never be greater than that resulting from the force of the spiral spring.

But in order that my Invention may be more clearly understood, I will proceed to describe the same by the aid of the accompanying Sheet of Drawings, in which Fig. 1 is a plan view of the instrument in which the inner end of the volute tube is fixed; Fig. 2 is a transverse section of the same; Fig. 3 is a plan of the instrument in which the outer end of the volute tube is fixed; Fig. 4 is a transverse section of the same; Figs. 5 and 6 are vertical sections through Figs. 1 and 3, showing one arrangement for fixing the hand or pointer after a temperature has been taken or registered; Fig. 7 is a plan; Figure 8, a transverse section; and Fig. 9, a vertical section showing another arrangement for fixing the hand or pointer after a temperature has been taken or registered.

Referring to Figs. 1 and 2, A is the volute tube filled with a highly expansive fluid, such as ether or alcohol expanding in heat and contracting in cold. This tube is fixed at its inner end, and its outer or free end acts upon a rack B which gears with a pinion C, the spindle of which carries the pointer or hand D. The free end of the tube A is connected to the rack B by means of a pivot E secured to the former and working in a hole drilled in the latter. The spindle which carries the hand or pointer D is fitted with a hair spring H which serves, in the first place, to keep the teeth of the pinion C well against those of the rack B; and secondly, as its force is opposed to the action of the tube A, it serves to effect the final adjustment.

Referring to Figs. 3 and 4, in which the outer end of the volute tube A is fixed, an intermediate rack I is employed, against the side of which the free or inner end of the tube A abuts, either simply by means of an upright pin as shown, or by means of a pivot and hole as in the first arrangement above described. This rack I communicates its motion to a pinion K fitted to a second rack B gearing with the centre pinion C, the axis of which carries the indicating hand or pointer D. A hair spring H is provided on the axis of the centre pinion as in the first arrangement.

Immisch's Improved Thermometer.

In both these arrangements the tube A is enclosed in an open box formed by the two metal strips F secured to the case, and serving, first, to prevent the tube being bent by a violent shock; and secondly, to increase the heating surface.

The whole of the mechanism is enclosed in a suitable case L provided with a
5 suitably divided face and covered with a glass or crystal.

Referring to Figs. 5 and 6, one arrangement is shown for fixing the hand or pointer after a temperature has been taken or registered. The bow or handle M of the case is made movable permitting a motion of a quarter of a turn. The pivot of the stem reaches into the inside of the case L and carries an eccentric N against the
10 periphery of which rests the free end of a spring O fixed to the bottom surface of the plate P carrying the whole mechanism. This spring is fitted with a jewel end stone upon which the spindle of the centre pinion C carrying the indicating hand or pointer D runs. When the bow or handle M is turned upright the eccentric N permits the spring O to rise, thereby lifting the pinion C and pressing
15 its face against the under side of the bracket Q in which the top end of the spindle revolves. The friction thus produced resists the motion of the tube and fixes the indicating hand or pointer. On turning the bow or handle M back again, the eccentric N forces the spring O downwards, and the pinion is instantly released.

Referring to Figs. 7, 8, and 9, in which another arrangement is shown for fixing
20 the hand or pointer after a temperature has been taken or registered, a ratchet wheel S having very fine teeth is fitted to the spindle of the centre pinion C. A pawl or click T pressed lightly against the wheel S by a hair spring U prevents the hand from going back till the wheel is released by lifting the click or pawl T out of gear, either by means of the push piece V or by any other suitable means.

With self registering instruments it is advisable to make the outer extremity
25 of the rack B movably connected with the tube A in such a manner that ordinarily it would be held in its place by a spiral spring W fitted to the spindle of the rack. For this purpose the free end of the tube A is connected by a pivot and hole to a movable piece X mounted loosely on the rack spindle and held in place by the
30 spiral spring W, so as to abut against a pin Y fixed in the body of the rack. When the temperature has attained its greatest height the pawl or click T prevents the centre pinion moving back, but the tube A in receding carries the movable piece X with it, and on releasing the ratchet wheel S the spiral spring forces the hand to its proper position.

The bow or handle M is split so as to allow a long handle R to be introduced
35 and screwed into the stem if required.

Having now described the nature of my Invention and the manner of carrying the same into effect, I wish it to be understood that what I claim is,—

First. The construction of the improved thermometer, substantially as herein
40 described and shown in the Drawings, the essential feature of which consists in the employment of a volute tube, either filled with a highly expansive fluid, or exhausted of air, and the surrounding space of the case filled with a highly expansive and heat absorbing vapour, the expansion and contraction of which volute tube is caused by suitable mechanism to move a hand or pointer over a
45 suitably divided face.

Second. The modes of fixing the hand or pointer after a temperature has been taken, substantially as herein described.

In witness whereof, I, the said Moritz Immisch, have hereunto set my hand
50 and seal, this Fourth day of January, in the year of our Lord One thousand eight hundred and eighty-two.

MORITZ IMMISCH. (L.S.)

FIG. 1.

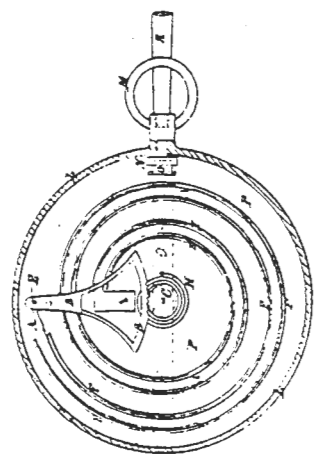

FIG. 3.

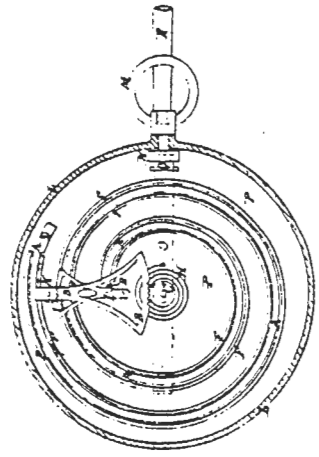

FIG. 7.

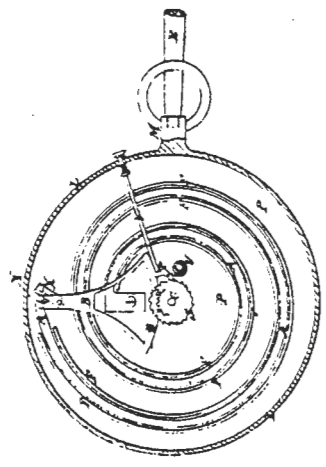

FIG. 5.

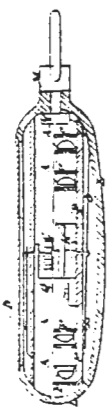

FIG. 6.

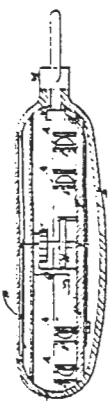

FIG. 9.

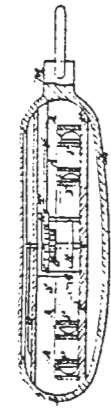

FIG. 2.

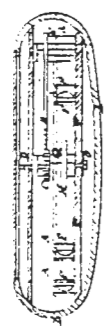

FIG. 4.

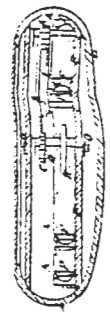
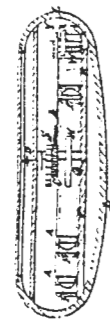

FIG. 8.



Bloodletting in Ophthalmology

Audrey B. Davis

Bloodletting is commonly dismissed as an antiquated and misguided medical treatment unworthy of consideration by western medical practitioners who rely often on scientific interpretations and technological advances to heal their patients. However there are lessons to be learned in tracing the theory and practice of bloodletting to control specific diseases. The efficacy of some modes of bleeding to arrest the acute stages of debilitating diseases motivated physicians throughout the nineteenth and early twentieth centuries to bleed patients with serious illnesses. One class of diseases in which bloodletting, particularly leeching, was recommended well into the twentieth century are those inflammations which attack tissues that control sight. A mechanical leeching device was designed in the mid nineteenth century to use in place of living leeches during the worst stages of the eye infections, iritis and choroiditis.

Ophthalmia was the early term for all inflammatory diseases of the eye. Ophthalmia remained the standard name into the first third of the nineteenth century, when inflammations began to be differentiated according to the individual eye structures which they attacked. The Scottish physician, William Mackenzie complained in 1833 in his influential book A Practical Treatise of the Diseases of the Eye that the term ophthalmia was too general and inclusive, and therefore, obscured knowing the differences between inflammatory diseases of the various eye structures with less success in their subsequent treatment. He explained that by identifying all eye diseases as ophthalmia, the focus of each type of inflammation and its unique pathology was not

properly accommodated. One type of remedy for an inflamed eye did not take into consideration the unique properties and problems encountered in healing each eye structure. Practice demonstrated that those remedies which cured an inflammation of the conjunctiva, aggravated diseases of the sclerotica or iris.

Mackenzie was not the first British physician to explicate the pioneering observations of Johannes Adam Schmidt. He benefitted from a translation produced in 1821 by George Monteath of Glasgow. Mackenzie proceeded to delineate the diseases of each section of the eye. Schmidt was drawn to the study and treatment of eye disorders by his teacher, Joseph Barth, a native of Malta, who founded and taught ophthalmic surgery in the University of Vienna beginning in 1773. When Barth retired in 1791 Schmidt, who was teaching anatomy and surgery, began to specialize in the eye after taking over his professor's classes. After a decade of concentrating on diseases of the eye Schmidt published his ground breaking book in 1801 entitled On Secondary Cataract and Iritis after the Operation for Cataract. He differentiated a number of eye disorders. Schmidt's monograph on diseases of the iris was soon incorporated into the German textbook literature such as in the second edition of Georg Joseph Beer's two volume work on Diseases of the Eye published in 1813 and 1817. The first important notice of Schmidt's book appeared in a lengthy and laudatory unsigned review published in The Quarterly Journal of Foreign Medicine and Surgery, volume 1 in 1833.

The most important and difficult to treat eye diseases delineated by Schmidt were iritis and choroiditis. One of the treatments he recommended which continued to be taught into the twentieth century was bloodletting. Inflammations of the iris were classified according to the systemic diseases out of which they were believed to develop including rheumatism, syphilis, scrofula and arthritis. Bloodletting

was recommended to cure all forms of iritis in its early stages on the theoretical grounds that it was an antiphlogistic form of treatment growing out of the Brunonian doctrine that a powerful antiphlogistic or weakening regime was needed to rid the body of disease which nature had no power to cure. The main features of this treatment consisted of deprivation of food and extensive leeching of the patient all over the body with from ten to fifty leeches. Schmidt's views about the multiple forms of iritis and their treatments were taught to American physicians at about the same time they were brought to Great Britain. S. Littell, Fellow of the College of Physicians of Philadelphia, in 1837, and in a second edition in 1846 of his Manual of the Diseases of the Eye promoted the use of venesection to treat eye inflammations "when the state of the constitution will permit its employment..." He further stipulated that "...the repeated abstraction of blood by cupping from the temples, and back of the neck, with an active cathartic in the beginning, and the rigid observance of the antiphlogistic system, will always be proper." Littell modified his view in 1846 when he stated that venesection should be done by the "local abstraction of blood by leeching from the temples, or cupping from the back of the neck--repeated as circumstances may require--" (p. 141)

Mackenzie described in detail the forms of bloodletting of most value in treating diseases of the eye. These were "opening a vein of the arm, the application of leeches round the eye, and division of the inflamed conjunctiva." Stronger measures such as opening the temporal artery, the external jugular vein or the nasal vein, or cupping the temples Mackenzie seldom found necessary. Each mode of bloodletting was not interchangeable however, and could not be substituted one for another. In fact there was danger "of losing the eye,...if an attempt was made to cure by local bleeding what will readily yield to general

bleeding, or vice versa." (p. 266) Mackenzie explained why each type of blood letting should be selected carefully to cure a specific iritic ophthalmia. He pointed out that "bleeding at the arm, by depressing the general strength of the patient, rather aggravates than alleviates the scrofulous ophthalmia, while bleeding with leeches, by removing local turgescence, greatly relieves them; a check is readily put to most of the internal ophthalmia by general bloodletting, while local has comparatively but little effect; in chronic puro-mucous conjunctivitis much more good is done by scarifying the inside of the eyelids, than could be accomplished by leeching or phlebotomy. Neither is it important in what succession we employ these three modes of taking away blood." As was the practice in selecting the specific methods of bloodletting for most diseases, the type of bloodletting chosen depended on the constitution of the patient. Mackenzie expressed the value of taking "Blood from the arm .. from a large opening...to ensure...a considerable effect on the impetus of the circulation. The quantity removed will vary from ten to thirty or forty ounces, according to the constitution of the patient, and the circumstances of the disease."

Mackenzie suggested that leeches be applied to the temple, forehead, and the side of the nose rather than to the loose substance of the eyelids. In some chronic cases of inflamed and thickened conjunctiva, one or two leeches might be fixed on the internal surface of the eyelids. The number of leeches to apply to other body parts varied from one to twenty or more.

Scarification of the conjunctiva of the eyelids, and less frequently, the covering of the eyeball was useful in some instances. One or two deep incisions along the whole length of the inner surface of the eyelid would produce a considerable discharge of blood. Along with scarification, snipping across the individual enlarged vessels running

over the surface of the eyeball was also useful. No longer sanctioned was the practice of removing a circular portion of the conjunctiva around the cornea as had been advised by Antonio Scarpa, the Italian anatomist and surgeon in his text on ophthalmology published in 1801. (p. 267)

Mackenzie emphasized the graveness of "iritis ... which often exists independent of inflammation in the other membranes of the eye such as conjunctivitis, sclerotitis, or corneitis; and on account of the important functions which the iris performs, as well as of the insidious and dangerous nature of the complaint, this disease is more deserving of attention than other diseases. The chief danger of iritis is due to the fact that this disease may produce adhesive inflammation, so that in the course of a few days of a neglected or misunderstood attack, the pupil may become completely and irreversibly obliterated by an effusion of coagulable lymph." (p.350)

Therefore it was essential to recognize the symptoms of an inflammation of the iris quickly. The most indicative physical changes included the appearance of fine hair-like vessels running in radii towards the edge of the cornea and discoloration of the iris. W. Lawrence F.R.S. and Surgeon to St. Bartholomew's Hospital in London proclaimed in 1834 in his text A Treatise on the Diseases of the Eye that change in color is one of the most striking characteristics of iritis. "A light colored iris assumes, under inflammation, a yellowish or greenish tint; occasionally, it is distinctly yellow; and, if the eye be blue. a bright green is sometimes seen. Generally, however, the tint, whether yellow or green, is of a dull and muddy tint and darker than in the sound state. In case of the iris being naturally dark-colored, it presents, when inflamed, a reddish tinge. Together with these changes of color, there is a complete loss of its natural

brillancy; it becomes dull and dark, and the beautiful fibrous arrangement, which characterises it in a healthy state, is either confused or entirely lost." (p. 227) Another symptom is contraction, irregularity and immobility of the pupil. A fourth symptom is effusion of coagulable lymph into the pupil and posterior chamber. Adhesions of the iris and especially the pupillary edge, to the capsule of the lens and in some cases to the cornea comprise the fifth symptom. A sixth symptom is weakened sight and sometimes almost total blindness, and finally, the last major symptom is pain in the eye. (p. 351 MacKenzie)

The causes of the inflammation of the iris are several. They include exposure to atmospheric changes and especially to transitions from heat to cold which leads to rheumatic iritis; constitutional syphilis; strumous inflammation of the iris along with corneitis; arthritic iritis which seems to be connected with the gout and injuries such as operations for the cataract. Treatment for each type of iritis varied in the amount and type of bloodletting required.

Local bleeding was not sufficient to remove iritis even of a moderate severity. General bleeding must be done immediately and repeated until the constitutional irritation was abated. Leeches were then to be applied freely around the eye and repeated every day until the inflammation was subdued. For rheumatic iritis the degree of swelling present determined the type and extent of bleeding. Repeated venesection was almost always necessary, followed by liberal application of leeches around the eye. Blood-letting was rarely necessary in syphilitic iritis. Although, George C. Monteath, author of a Manual on Diseases of the Human Eye (1821) claimed: "I differ decidedly from those who put their whole faith in mercury in the cure of this species, to the exclusion of other remedies, such as bleeding, blistering, etc. In my own practice, I have seen the disease running on with rapid

strides . . . , notwithstanding the full action of mercury, and its further progress at once arrested by a full bleeding from the arm, and a blister on the hind-head." (p. 367-MacKenzie) In arthritic iritis general bleeding was not advised and was believed to aggravate the disease. Local bleeding with cups and leeches could be cautiously applied.

The disease for which bloodletting was the most important treatment was inflammation of the choroid. Its major symptom was dimness of sight. "All objects to one or the other side of a perpendicular line, or above or below a horizontal line, appear dim, confused, and as if double, even when viewed with one eye". Later the eye appears red or blue. If the disease, which is restricted to adults, continues total blindness occurs. Fever and digestive diseases often accompany choroiditis. The causes of the disease were lack of exercise, dysfunction of the stomach and bowels, overuse of the eyes and over exposure to heat and light, especially the glare of hot fires and blows to the eye. Mackenzie claimed: "Profuse and repeated bloodletting does more good in the early stage of choroiditis, than all other remedies put together." (p. 385) Since there may not be external signs of inflammation bleeding may not appear necessary, or if undertaken may consist of a few leeches applied, when a tempora^l artery should be opened to remove a large quantity of blood. Bleeding from the jugular vein, or from the arm, is also highly useful. Twenty-four or more leeches around the eye, every second day also produces good results.

For Mackenzie all eye diseases were not curable by bleeding alone. Diseases for which bloodletting was recommended "...require other remedies besides the taking away of blood; and therefore, while we value this means of cure very highly, we must by no means trust to it alone in any case." (p. 266)

Bloodletting diminished as other medical techniques, aided by

instruments were introduced in the nineteenth century, but it never disappeared, especially where it served as a therapy which could not be surpassed in the acute phase of a disease. Leeching served this purpose in eye inflammations until the advent of atropin and other strong drugs. One of the technological spurs that improved and simplified leeching in treating eye disorders was the invention of the artificial or mechanical leech. With this new instrument some of the difficulties of applying living leeches could be avoided. The most successful artificial leech was designed by the French urologist, and originator with Civiale, of lithotrity (1824-31), Charles Louis Heurteloupe. Shortly before his death in 1864 Heurteloupe invented a device consisting of two parts, one a spring scarificator that made a small (5 mm) circular incision in imitation of the natural leech, and a suction pump attached to a glass cylinder which held up to an ounce of blood. In the pump a piston was raised by a screw to withdraw the blood. It was applied to the temples for the treatment of eye disorders. (p. 38 Davis and Appel) Other artificial leeches based on Heurteloupe's principle were manufactured such as Luer's Leech. Another unusual artificial leech which functioned without the cumbersome piston was patented and sold by George Tiemann and Co of New York. It differed from the Heurteloupe leech in employing ether to remove air from the glass tube. "To expel air from the tube, a few drops of ether were placed on it, after which it was immersed to its mouth in hot water until the ether vaporized. The tube was then applied to the skin and allowed to cool, thus sucking blood from a wound made by the scarificator, a long metal tube that was rotated to make a circular incision." (p. 38 Davis and Appel) The Tiemann leech substitute was light, cheap and did not require two hands to hold it while in use.

Periods of resurgence in the use of bloodletting also arose in response to the experiences of physicians who extolled its virtues. In

1871 Dr. C.C.P. Clark of Oswego, New York observed "many signs in medical journals and elsewhere, of renewed attention on the part of the profession to the subject of venesection" which he regarded as a good omen." (Medical Record p 319 vol 6 "Obsers in Bloodletting") His own success in using bloodletting was compelling. "Dangerous though it be with the dangerously sick, there are familiar facts which go to show, that even in the prostration that accompanies long-continued fevers, the loss of blood may be not only innocent but salutary." (p. 319) Clark's use of bleeding centered on the treatment of inflammatory and congestive diseases. It is in the early stages or beginning of "...inflammatory and congestive diseases that the lancet finds its chief place. ... (during) inflammations and congestions of ... organs, when the capillaries of the affected part have not yet lost their power of rallying; (p. 319)

Clark summed up his practice over a generation. "On the whole I am certain of having saved more lives by the lancet than by any other means except opium, and I am more certain of having saved some by that instrument than even by opium itself."

Shortly before in 1867 the New York Academy of Medicine discussed "The Question of Blood-Letting." Alfred C. Post, President remarked that "in acute inflammations and in active determinations of blood to important organs, the blood-letting plan of treatment was of substantial value. It relieved local pain." (p. 473 Medical Record vol 2 1867-68) To prove his point Post noted that a patient suffering from "a somewhat intractable iritis, when first seen by him, had lost no blood during the early stage, his gums had been touched, he complained of pain and impaired vision, his pupil was irregular, etc. Having a firm resisting pulse, he was bled by the house surgeon under my care. The inflammation then began to pass away very rapidly." (p. 473)

Before the invention of the ophthalmoscope by Hermann von Helmholtz in 1851 there was good reason to question how some eye diseases were classified as separate entities. Without the ophthalmoscope choroiditis and retinal inflammation were indistinguishable. However at the end of the nineteenth century the division of iritis into several forms including: rheumatic, arthritic, syphilitic, etc. was challenged for another sound reason, that of treating these major systemic diseases while neglecting the accompanying iritis until it became incurable and resulted in blindness. Robert Randolph of Baltimore in a chapter on "Diseases of the Iris, etc." included in De Schweinitz and Randall's text An American Text-Book of Diseases of the Eye, Ear, Nose and Throat published in 1899, warned of the danger of identifying iritis with these major diseases. He cited Robert Brudenell Carter (1876) and W. Adams Frost to bolster his position. He reasoned: "There is one ground, however, on which I strongly object to this ticketing of iritis with the names of various diseases--namely, that habit is likely to mislead the inexperienced practitioner into an endeavor to treat the name on the ticket, while the iritis may be neglected until it has done irreparable harm. I do not know of any disease which prevents the occurrence of iritis, and hence I do not know of any with which it may not sometimes be associated...." (p. 341) In addition to the use of atropin and cocain and dry or moist heat poultices to relax the iris and stop the normal movements of the pupil, Randolph recommended bleeding with some reservations. "Four or five leeches applied to the temples or the artificial leech (Heurteloup) are helpful in bringing about an abatement of the inflammatory symptoms, although this method of treating iritis has become less popular of late years. The Japanese stove or hot box is a most convenient method of applying dry heat." (p. 342)

At the turn of the century Ernst Fuchs, an outstanding teacher who continued the tradition started by Barth in the eighteenth century at Vienna, in the second English edition of the fifth German edition of his Textbook of Ophthalmology attested to the continuing value of bloodletting in certain eye infections. Fuchs stated: "While bloodletting has pretty much disappeared from general practice, in ophthalmology it has remained in use up to the present time, and rightly, too, since in suitable cases striking and undeniable advantage is often seen to accrue from it." (p. 346 and p. 379, 3rd ed. 1908)

Fuchs recommended the use of leeches applied behind the mastoid process or the use of Heurteloupe's artificial leech. In the former case six to ten leeches should be used; when using Heurteloupe's leech the glass cylinder should be filled once or twice. The point of application is either the temple or the skin behind the mastoid process. With inflammations of the conjunctiva, the iris or the ciliary body the temple is the preferred place to withdraw blood. (p. 379)

More details on placement of the leech and the amount of blood to withdraw were provided by Edward Jackson in his text A Manual of the Diagnosis and Treatment of the Diseases of the Eye published in 1900. Jackson who taught ophthalmology in Philadelphia and had served as President of the American Academy of Medicine explained that the loose tissue of the eyelids was prone to excessive swelling after a leech-bite so that it seemed preferable to place the leeches on the temple, which may be pricked until blood appears to attract and to induce the leeches to bite and remove more blood. Each American leech will withdraw about one fluid-dram of blood and the European leech takes out four times as much. (p. 529) To provide the maximum in relief from the pain of severe ocular inflammations Jackson advised the use of the artificial leech, probably Luer's, which consisted of a circular knife made to cut with a

rotary motion and a glass cylinder that can be exhausted of air by a screw-piston. From one to four ounces could be taken from the temple with this instrument.

Charles H. May (1861-1943) of Columbia University, another outstanding teacher, produced a popular text which was reprinted and revised in seven editions. May presented "a concise, practical, and systematic Manual of the Diseases of the Eye, intended for the student and the general practitioner of medicine." (p. iii-first ed) In the seventh edition which appeared in 1911 the author stated "...that every page has been carefully examined, many alterations have been made, and numerous paragraphs added on subjects. (p. iii) May also reiterated that "local blood-letting is of great benefit in affections of the deeper structures of the eye, especially in iritis". Two to four leeches applied to the temple, midway between the outer canthus and the tragus was the method he recommended. For those who prefer, the artificial leech could be used to abstract an ounce of blood.(p. 371) May's personal artificial Heurteloupe Leech is preserved in the Armed Forces Medical Museum.

An important textbook on ocular diseases was published by A. Maitland Ramsay in 1920. In the foreword to his book Clinical Ophthalmology for the General Practitioner Sir James Mackenzie of Edinburgh endorsed Maitland's text as being unusually original and based on his own clinical experiences. Mackenzie renowned for his superb diagnostic skills which did not depend on instruments, argued that "When one reflects that probably 95 per cent of the cases a general practitioner meets in daily work are undiagnosable from the textbook point of view, the conclusion is forced upon one that it is time a change was made in the authorship of these books. The reason that text-books assume their peculiar features is that disease has been

classified on the basis of the pathology of individual organs. The pathological state is not recognized until the disease has advanced so far as to produce a physical sign or until the patient has reached the post-mortem table. As, however, people with impaired health rarely show these characteristic signs, and then only late in their history, it is manifest that the text-book description can only refer to advanced stages of disease. As the vast majority of people whom a general practitioner sees are people without those physical signs of advanced disease, it can be seen why text-books are so useless. Dr. Ramsay recognized this truth and wrote a text-book for the general practitioner, drawing his information from his own experience and not copying the beliefs and superstitions of his predecessors." (p. x)

Thus it is especially interesting to see what Ramsay's experiences led him to recommend for treating eye inflammations. Ramsay observed that the three chief items to treat in iritis were to dilate the pupil, subdue the pain and combat the constitutional disorder which produced the disease. To remove the pain he recommended a combination of cocain and dionin with atropin, "but of even more value than these are the local application of heat or of cold, of leeches, and the use of mercury and anodynes internally." (p. 159) These latter measures were to be used especially when the symptoms were severe. He further explained that "When the signs of inflammation are very acute, the pain excruciating, and the photobia intense nothing affords such quick relief as local blood-letting. This is usually carried out either by natural leeches, or by Heurteloup's artificial leech. Leeches are best applied around the external canthus, or over the mastoid region. The amount of blood which should be withdrawn will vary according to the individual case, but, generally speaking, the bleeding should be continued until the pain is relieved. No one can deny the great value of blood-letting

in the treatment of a recent case of acute iritis, for after the application of three or four leeches to the temple the pain lessens, the patient is able to open his eye, and the pupil now yields to the influence of atropin, though previously the drug had been inefficacious, or had even caused increased irritation." (p. 160) Ramsay described the application of the leech. He said it should be placed in a narrow tube and placed over the spot, which may need to be moistened with a drop of milk to induce the leech to suck. The leech should be allowed to stop of its own accord. The mechanical leech is cumbersome and some physicians found it unwieldy to use, hence the continuing popularity of the living leech. Leeching was recommended specifically for iritis and choroiditis. (p. 452)

For 120 years after the discovery and description of the several inflammations of the eye, blood-letting served as a staple among the forms of therapy for some of the most severe of these diseases. The types of bloodletting and the methods of removing the blood varied as the technology for removing blood changed, or the experience of the physician dictated, but the necessity of removing blood through leeching and cupping in severe and painful iritis and choroiditis was repeated throughout the period by European and American authors of the foremost text books and manuals on diseases of the eye. These inflammatory diseases of the eye are difficult to treat and their origins often still are unexplainable. Repeated attacks occur. Current therapy, including the use of powerful drugs with numerous secondary effects are curative in many instances, but require caution in their application.

Captions

1. M 004,031 Heurteloup artificial leech owned by Dr. Charles H. May and donated to the Armed Forces Institute of Pathology in 1939.

2. Leech set donated by the Medical Collectors Association to the National Museum of American History of the Smithsonian Institution in 1986. The kit contains four glass cylinders of varying diameters fitted with pistons covered with a heavy cloth. The metal discs are mounted on the ends of the cylinders to seal the glass to the skin and prevent the glass from puncturing the skin. The brass trephine contains a sharp edged cylinder at its tip which is twirled like a top by pulling a string wrapped around it, to cut a small round hole in the skin. The glass cylinder is then placed over this spot and the blood collected by evacuating the space below the piston.

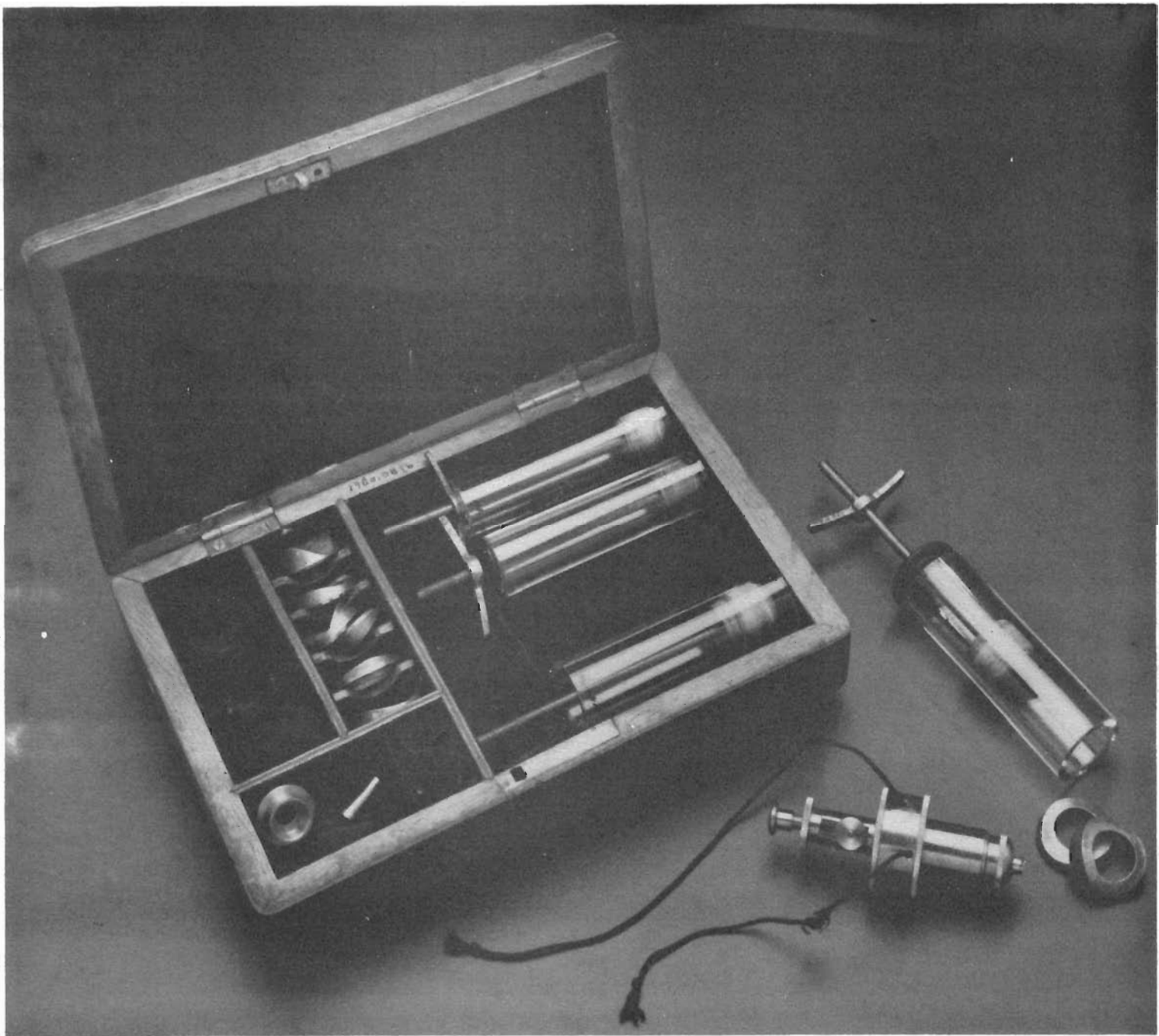

FIGURE 1

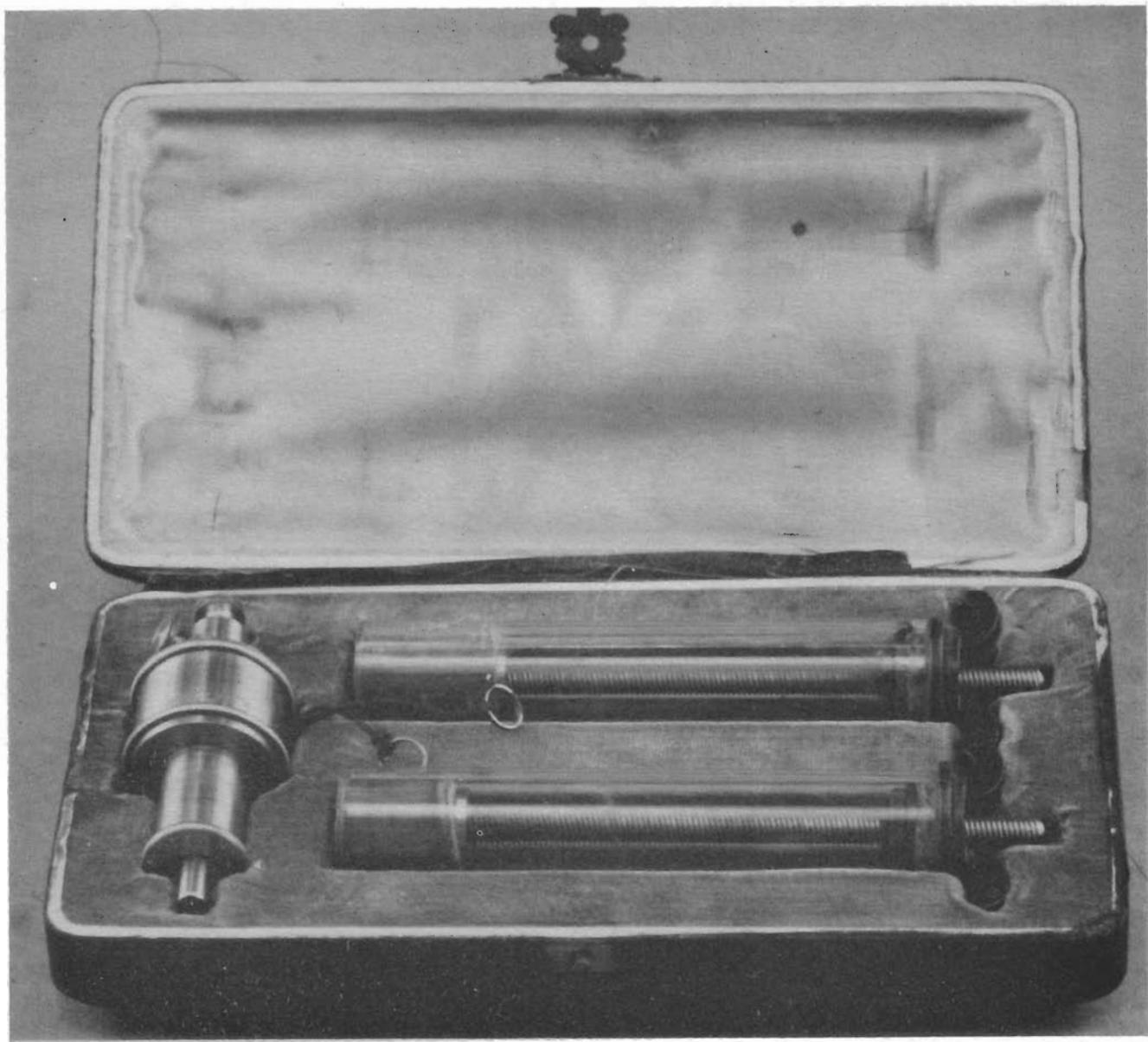

FIGURE 2

2

LITHOTRIPSIE.

MÉMOIRES

SUR

LA LITHOTRIPSIE PAR PERCUSSION,

ET SUR L'INSTRUMENT APPELÉ

PERCUTEUR COURBE A MARTEAU,

qui permet de mettre en usage ce nouveau système de pulvérisation
des pierres vésicales;

LE TOUT APPUYÉ DE NOMBREUX EXEMPLES DE GUÉRISONS BIEN AUTHENTIQUES

présenté à l'Académie des Sciences,

PAR LE BARON HEURTELOUP,

DOCTEUR DE LA FACULTÉ DE MÉDECINE DE PARIS.

Avec une Planche.



PARIS,
CHEZ BÉCHET, LIBRAIRE,
PLACE DE L'ÉCOLE DE MÉDECINE.

1833.

Compresseur volant pour faire agir
le percuteur par pression (démonté
sans le percuteur) (1/3 de grandeur)

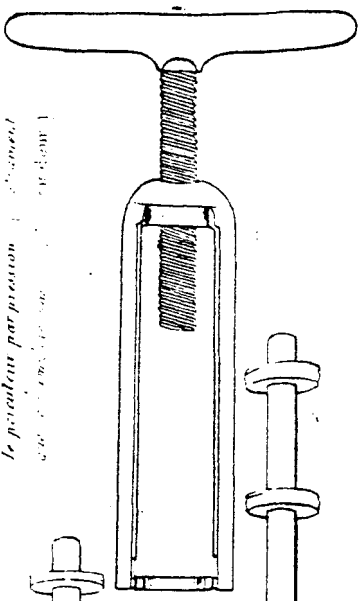

Le Percuteur fermé (demi grandeur)

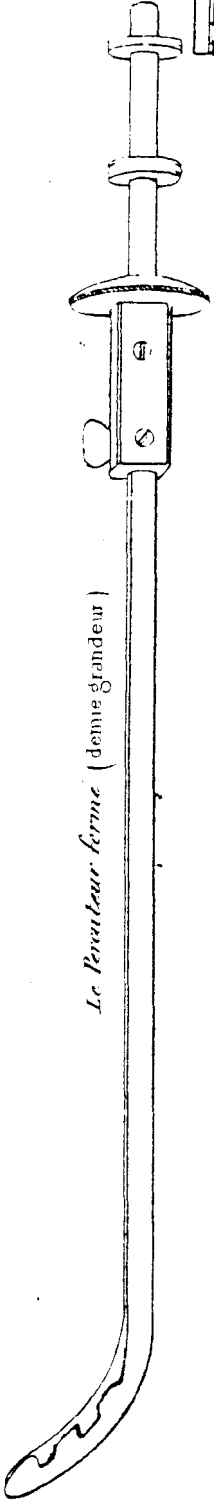

Le Percuteur ouvert (demi grandeur)

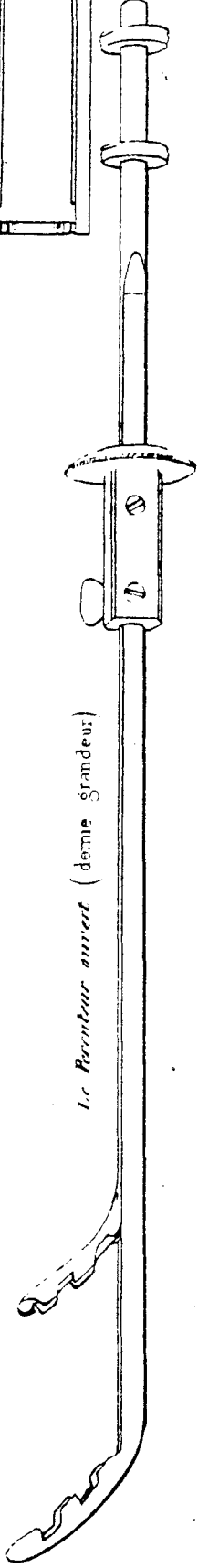

Le Marteau (demi grandeur)

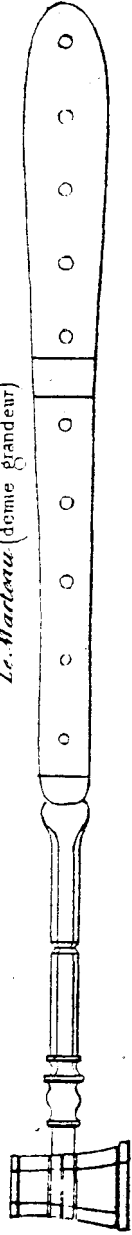

Point fixe vu de profil,
avec le percuteur placé
dans la mortaise
(1/3 de grandeur)



Point fixe vu de
face (1/3 de grandeur)

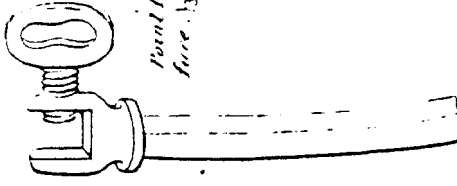

Le Percuteur, le point fixe
le coin et le lit rectangle
disposés comme lorsque
la pulvérisation de la
pierre va être opérée par
le marteau 1/8 de grandeur

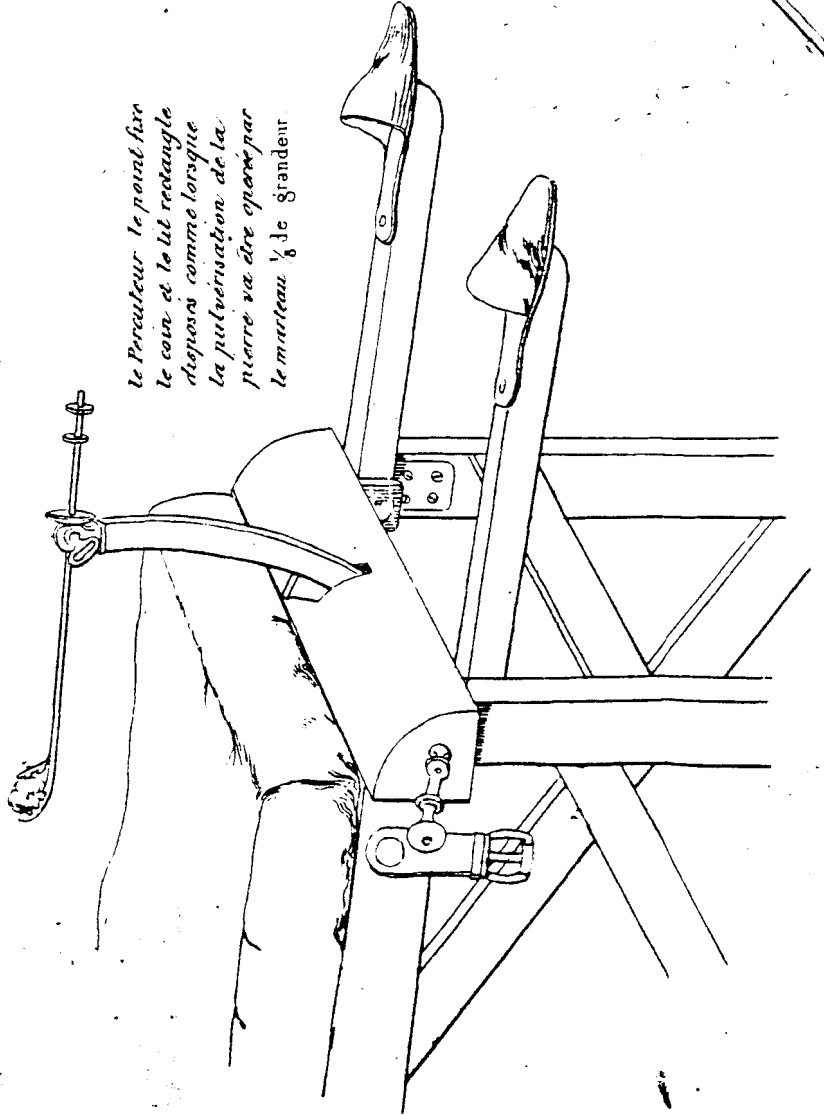

Le Coin
(demi grandeur)

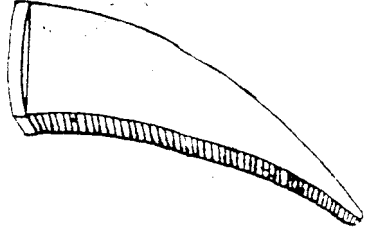

MEDICAL MUSEUMS OF THE WORLD

PART VIII

AUSTRIA

BY

PROFESSOR E.T. PENGELLEY

AUSTRIA

Austria, like its neighbor Switzerland, is one of the smaller mountainous countries of central Europe. Before World War I it was part of the huge Austro-Hungarian Empire, and for a short time before and during World War II it became an integral part of Germany. However, it emerged from this latter struggle as a modern independent state.

Austria has always had a society of high culture, centered on its capital, Vienna, astride the banks of the Danube. From our point of view, however, it is important that medicine flourished here particularly in the 19th century when medical students from all over the world came to Vienna if possible. Vienna is still a leading centre of medicine, and there is much of historical interest that still survives.

VIENNA

Location - At the eastern end of Austria, and about 450 kilometers from Munich in southern Germany.

Train - From many parts of Europe direct.

Road - From Munich take the E11 Autobahn to the east, and at Salzburg join the E14 to Linz, and finally the E5 to Vienna.

Institut für Geschichte der Medizin der Universität Wien
Josephinum
Währinger Strasse 25
Vienna

Opening Hours: Monday - Friday 9.00 - 16.00. Guide books and other literature are available, some of them in English. There is a small charge for admission.

This is an institute for the history of medicine and is part of the 600 year old University of Vienna. However, as an institute it is unique in having one of the best medical museums in the world.

The Josephinum, where the institute and museum are housed, was built about 1785 at the command of the Emperor Joseph II (1741-1790) -- who is generally considered by historians to have been an "enlightened monarch". The building was constructed to house an academy for the formal training of surgeons, mostly for the benefit of the army. Still, this was one of the first formal schools of surgery and from which part of the excellence of Viennese medicine derives. It is important also that the Josephinum is considered one of the most beautiful buildings in Vienna, the architect having been an Italian, Isidore Canevale (1730-1786).

As early as 1850, there was a chair of the History of Medicine at the University of Vienna, but it was not until 1920 that the great historian of medicine, Max Neuburger (1868-1955), transferred the History of Medicine Institute to the Josephinum and also established the museum there. Fortunately

both have since prospered, and today it is a great experience to visit the Josephinum.

The museum is large and I can only highlight its main exhibits here. First and foremost is its huge (1192 specimens!) "Collection of Anatomical and Obstetric Wax Preparations". This collection, commissioned by Joseph II, was modeled in Florence from the wax of wild bees between 1775-1785, and for many years subsequently was the means by which army surgeons learned their anatomy. The happy combination of artistry and accuracy in the wax models is truly remarkable, and it is difficult to put into words their visual effect. They are all in cases of handblown glass inlaid in Rosewood. Two centuries of wear and tear have taken their toll, but fortunately the whole collection is being gradually and meticulously restored.

Other main exhibits in the museum show the development of medical teaching, ophthalmology, hygiene, brain function, surgery, pathology, blood grouping and many more. Also the early development of many modern medical instruments, much of which took place in Vienna. As I have stressed this museum is extensive, and many interesting hours can be spent there even by a casual visitor.

Finally in this Institute of the History of Medicine is a magnificent historical library of medicine. Some of its holdings go back to the 15th century, and it has virtually every major medical work published since then. The library can only be used by professional scholars, with the permission of the librarian, but visitors can ask to see it. The library also has an extensive collection of medical manuscripts and portraits of famous doctors. Few people could fail to be impressed with this institute, and the role it plays in the culture of Austria and the world beyond. I was particularly impressed with the superb care of everything and the dedication of the staff.

Sigmund Freud Haus
Berggasse 19
Vienna

Opening Hours: Monday - Friday 10.00 - 13.00, Saturdays, Sundays and Holidays
 10.00 - 16.00. Guide books and other literature are available, many in English. There is a small charge for admission.

Sigmund Freud, the founder of psychoanalysis, lived and worked in this house from 1891-1938. It is now maintained as a museum.

Sigmund Freud

So much controversy, a great deal of which has been ridicule and misunderstanding, has surrounded the work and achievements of Sigmund Freud (1856-1939), that his name still conjures up sarcasm and derision. But there can be no doubt about his permanent place in medical history.

Freud was born in Freiberg, Moravia, now called Pribor and part of modern Czechoslovakia. His family was poor. When he was only 4 they moved to Vienna, and this became his home for most of his career. Freud was a keen student, and his family encouraged learning. He graduated with distinction from the

Gymnasium, and at 17 entered the University of Vienna to study medicine. It took him 8 years to get his medical degree, mainly because he devoted much of his time to medical research rather than pursuing the prescribed curriculum. However, in 1881 he got his degree and joined the staff of the famous Allgemeines Krankenhaus, where he specialized in neuropathology. In addition to his clinical activities he carried out research on the anatomy of the human brain. At this period in his life he is said to have become addicted to cocaine which he found enabled him to work well. If this was the case he was apparently able to give it up later.

After a short study trip to Paris, Freud set up practice in Vienna as a neuropathologist, and in the same year, 1886, he married Martha Bernays who became his life long companion. With the beginning of his private practice, Freud also started active research into what we now call psychoanalysis. Fortunately he was on the staff of the medical faculty of the University of Vienna, which gave an outlet for his very new, and to some people "alarming", ideas. During the years which followed, Freud made known his theories and ideas in various books and journals. It is generally considered that the most important book he wrote was "Die Traumdeutung" (The Interpretation of Dreams). This came out in 1900, and contains all the basic concepts of psychoanalytic theory and practice: the erotic nature of dreams, the "Oedipus complex", the libido and many others, all related to the subconscious. It was greeted with a storm of hostility and abuse, which has not yet died away, but the book has survived as one of the great works of medicine. Obviously some of Freud's ideas have been superceded, but considering that he was dealing with something so complex as the human mind, it is remarkable how accurate he has proved to be.

At the age of 67 and at the height of his fame and career, Freud developed cancer of the jaw. For the rest of his life he was a martyr to this. He underwent many operations, suffered severe pain and eventually died from it. The last years of his life were saddened by the coming of the Nazi regime in Germany. Freud was Jewish, and when the Nazis took over Austria in 1938 he and his family had to flee to England where he found sanctuary (see under London, Hampstead). He died there the following year. He was 83.

The Sigmund Freud Museum is on the Mezzanine floor of Berggasse 19. It was here that he lived and worked. The museum consists of 4 rooms. The first of these was the waiting room for his patients. This contains the original furniture, and was restored with the help of his daughter, Dr. Anna Freud, who knew it well. The second room was his consulting room, which was almost perfectly soundproofed. Much of the original furniture of this room is in London, but photographs on the walls clearly depict everything as it was when in use. The third room was the sitting room of the family, and contains mementos of many episodes in Freud's life. Finally there is the foyer, where there are now books, portraits, etc. for sale. There are other rooms here which he occupied, but they are not open to the public.

A visit to the Sigmund Freud Haus brings one in close touch with a man whose legacy has benefited millions of people in trouble, and whose name is likely to live as long as humans survive.

Allgemeines Krankenhaus
Alser Strasse 4
Vienna

Opening hours: Normal business hours. This is a working hospital.

This is the Vienna General Hospital. It is an enormous complex today, and has in the past played a huge role in the development of modern medicine. It was founded in 1693, but the main buildings date from the 18th century. It was here that Ignaz Semmelweis (see under Budapest, Hungary), Sigmund Freud and many others worked. This was also the centre of the great period of Viennese medicine in the 19th century. Obviously one cannot visit the wards, clinics, etc. of the hospital, but one can walk through the enormous and very lovely courtyards.

Universität der Wien
Dr. Karl Lueger-Ring
Vienna

Opening hours: Normal business hours.

This is the main building of the University of Vienna. It is worth a visit, simply because it is one of the great universities of the world where many famous doctors, etc. have studied and taught. Nearby is the Dr. Ignaz Seipel-Platz where some of the buildings of the "Old University" survive.

In conclusion I must point out that Vienna is famous not only for its medicine, but perhaps above all for its music, and the visitor will surely want to see some of the many interesting places in the history of music.