

MEDICAL



COLLECTORS



ASSOCIATION

NEWSLETTER NO.7
July 1986

Dear Colleagues:

The Association continues to grow in membership and activity. A number of interesting articles have been devoted recently to medical collecting and more and more dealers appear to be entering the market. Probably the single most important item of news is concerning the initiation of an annual meeting by the group. On April 18th the Medical Collectors Association had its first annual meeting which was held at the Smithsonian Institutions and hosted by Dr. Audrey Davis. The meeting was attended by 33 members and 13 guests. Dr. Davis told us about the collection and was kind enough, on the day preceding the meeting, to host several small tours of the "behind-the-scenes" activities of the medical group at the Smithsonian. After her introduction in the morning, formal presentations were made by me, on the History of the Development of Methods for Measuring the Blood Pressure, Dr. William Helfand on Medical and Pharmaceutical trade cards, and by Dr. Gordon Dammann on Civil War Medicine. The meeting was in a very relaxed atmosphere with a considerable amount of discussion and "give and take" between the audience and the speakers. The conviviality and congeniality of the session, I think, set the tone for future meetings which we all look forward to with anticipation. In the afternoon a dealers' session was held at the Marriott Hotel and there was an hour or so of very active trading and an opportunity for many of the members and dealers to meet each other first-hand. That evening 17 attended a dinner at the Marriott which was truly a special experience. It was great fun to have a chance in this relaxed atmosphere to discuss our mutual collecting interests. Alex Peck was kind enough to treat us all to drinks prior to dinner, which certainly helped to relax the proceedings. In addition, an unexpected but gratifying outcome of the meeting is a modest profit. Since the coffee and danish were inexpensive, the Smithsonian did not charge us for the use of the facilities, and because we had an adequate number of rooms reserved the hotel waived the fees related to the dealers' exhibit. This left us with a surplus of \$690.37. This money has been sent to Dr. Davis and made out to the Division of Medical Sciences. It represents a contribution from the Medical Collectors Association to the Smithsonian Collection and we all hope it will be used to good advantage.

The date and location for the next meeting has been set based upon the members preferences which were indicated at the meeting in Washington. The next meeting has been scheduled for Friday, May 8th, 1987, and will be held at the New York Academy of Medicine and hosted by me and the Academy. A room large enough to accommodate between 50/100 persons has been reserved and I am currently working on the program for the 1987 meeting. The next Newsletter, which will be distributed sometime in late November or early December, will contain explicit details concerning the meeting and forms for registration. A requirement of the Academy

Founder: M. Donald Blaufox, M.D., Ph.D.

is that any meeting there be open to their own membership and I am hopeful that a number of members of the History of Medicine section of the Academy will attend and perhaps even participate in the formal proceedings. In order to provide the dealers with adequate representation, I have asked Judith Flamenbaum, along with the Coffeen's and the Wiedenkeller's to constitute a committee which will decide whether or not there will be a dealer exhibition at the time of the next meeting and, if so, to set up the guidelines for carrying out and financing that exhibition. The date of the meeting should be convenient. The Optical Fair will be held in San Francisco on April 18th, sufficiently far from the MCA meeting so as not to interfere with it, and the History of Medicine meeting is the week preceding the MCA meeting, so that those individuals who come east for the History of Medicine meeting, will have an opportunity to spend a few days in New York and attend the MCA if they wish.

Dr. Larry Vincent has very kindly offered to host the third Annual Meeting of the Medical Collectors Association, and our plans are for that meeting to be held at the University of North Carolina at Chapel Hill in 1988. Dr. Vincent is now putting together preliminary plans for the meeting and I am sure will be able to tell us more about it next spring. Volunteers for future meetings are urgently needed and will be gratefully accepted.

This second Newsletter of the year contains a number of interesting articles. The "Can You Identify" section has been considerably expanded with photocopies of catalogues describing a number of the items which have been identified. In addition, Dr. Richardson has sent in some alarming information about a form of antiquity which many of us may have been mistakenly attributing to the physicians' use, but which appears to probably have just been a butcher saw. Another surprising thing about medical antiques is the great difficulty in dating them and I have added some correspondence with the Sklar company which is quite interesting in that it informs us that a form of trephining drill apparently is of much more recent vintage than many of us had thought. Complementing this disclosure is another contribution from Alex Peck, this time highlighting the neurosurgical instruments which we all find so interesting and provocative.

Two articles have recently appeared about members of the Medical Collectors Association. A very nice article appeared in PHYSICIANS MANAGEMENT about Bob Kravetz and his collecting interests, and I have included copies of this article in the Newsletter. In addition, the NIH Newsletters had a brief description of Terry Hambrecht's collecting interests and Terry has been kind enough to send us some comments on cleaning and preservation of antique medical collectibles. This is a particularly interesting area. Many of us enjoy restoring our acquisitions ourselves, and I think all of us would appreciate any hints or tricks that have been learned during the years to help bring our antiques into a reasonable condition.

Another new addition to the Newsletter is an article which appeared in a Pfizer bulletin on the history of arthritis as art. Dr. James Goodwin and Pfizer

Pharmaceuticals were kind enough to consent to our distributing this to the membership and supplying us with very interesting reprints.

In addition to the new items, our serials continue with William Helfand's pharmaceutical column, as usual I have placed a piece of my own pharmaceutical ephemera collection on the back of his article, and Dr. Pengelley, in this issue of the Newsletter, takes us on to the medical museums of Italy.

A few other news items perhaps worth mentioning:

Dr. Fred Rosner has announced the publication of an English translation of Maimonides Treatises on Poisons, Hemorrhoids and Cohabitation, and also has available English translations of his medical aphorisms and of Julius Preuss' book Biblical and Talmudic Medicine. Individuals wishing copies of these volumes can contact Dr. Rosner at the Queens Hospital Center Affiliation, 82-68 164th Street, Jamaica, New York 11432. Most of you should all be aware by now that the Printer's Devil is publishing "The Bibliography of Medical Trade Catalogues", which has been compiled by Drs. Audrey Davis and Mark Dreyfuss. Information about this publication can be obtained from the Printer's Devil (Barry Wiedenkeller).

In addition, we have received an announcement of the establishment of the Stone Street Medical Museum in Rockville, Maryland. An announcement of the museum is contained at the end of the Newsletter. Persons interested in visiting it may refer to the announcement in the Newsletter containing the details of the address, hours, etc.

We are beginning once again to run low on materials. I am in desperate need of patent models and copies of patent applications. Photographs of the models should be submitted to me on flat finish, black and white photos, approximately 4" by 5". The "Can You Identify" column also is running low on material, similarly 4" x 5" black and white high contrast photos should be submitted for this. Articles, announcements, anything that would be of interest to the rest of us should be sent on. There's no need to write a covering letter, just photocopy what you have and send it on to the Medical Collectors Association, c/o me. I know that all of you have a great deal of material, I know that I see a significant number of things and you must also.

Have a nice summer, I hope you enjoy the latest of our Newsletters and I look forward to hearing from all of you.

**REMEMBER OUR SUCCESS DEPENDS ON CONTRIBUTIONS
AND SUGGESTIONS TO THE NEWSLETTER FROM THE MEMBERS**

CAN YOU IDENTIFY THIS

Material: Wood, Brass, Thermoplastic, Brass bound case

Maker: Arnold & Sons

Presumed Use: That's a give away

Date: 1860 - 1870

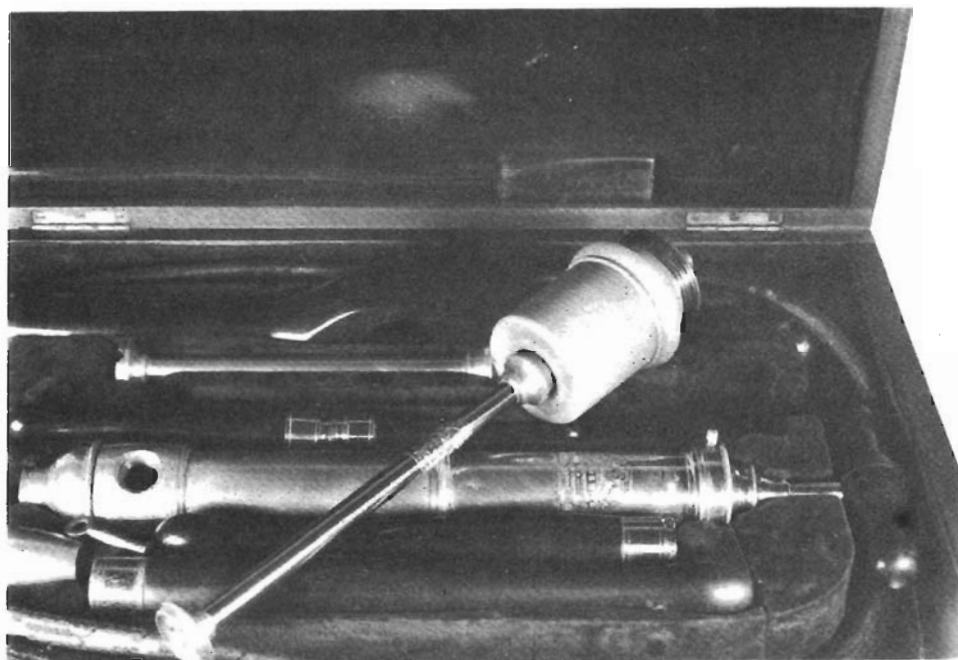
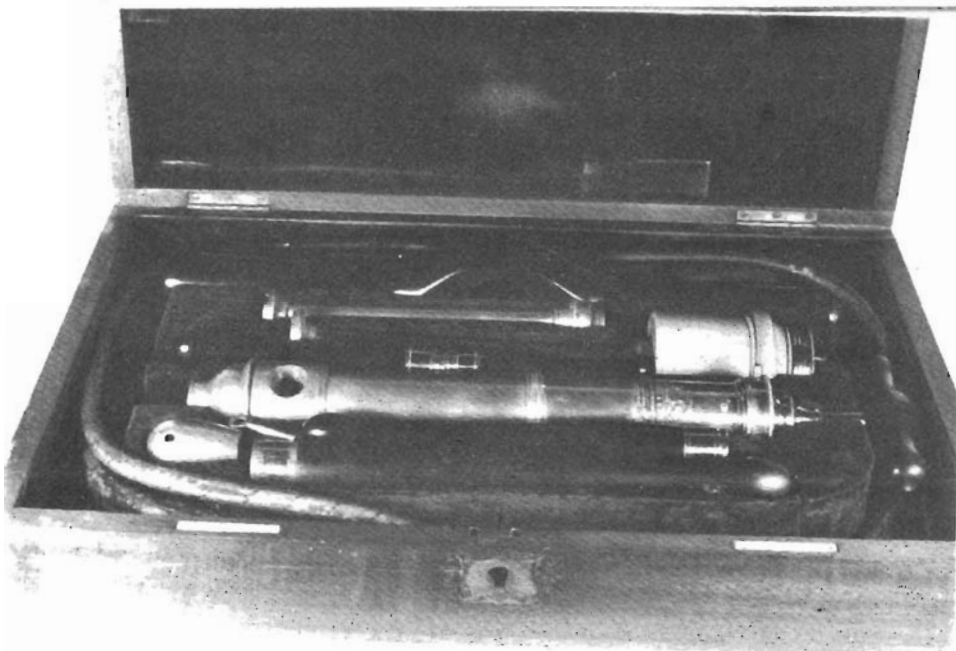

I think this is a:

From:

Please return to M. Donald Blaufox, M.D., Ph.D.

CAN YOU IDENTIFY THIS?

MATERIAL
MAKER
PRESUMED USE
DATE

Silver Plate
Evans and Wormull, 31 Stamford Street
Vaccine Warmer?
1880-1890

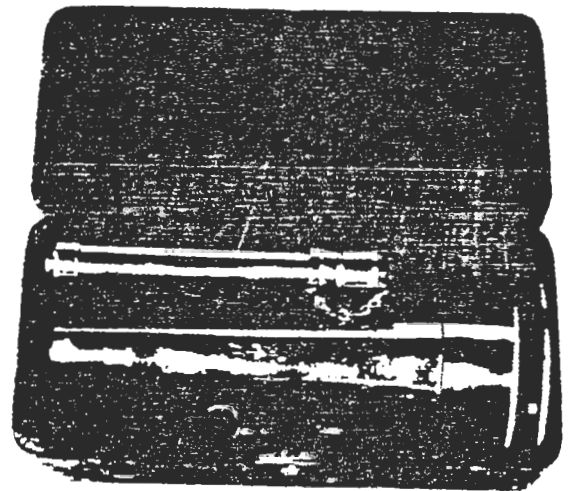
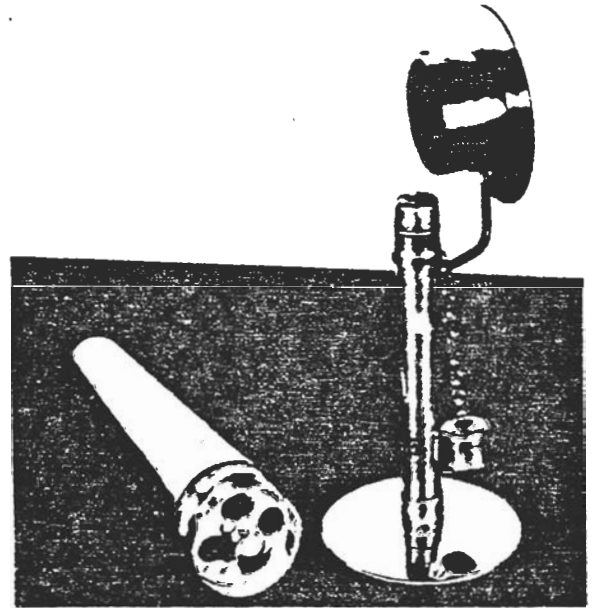
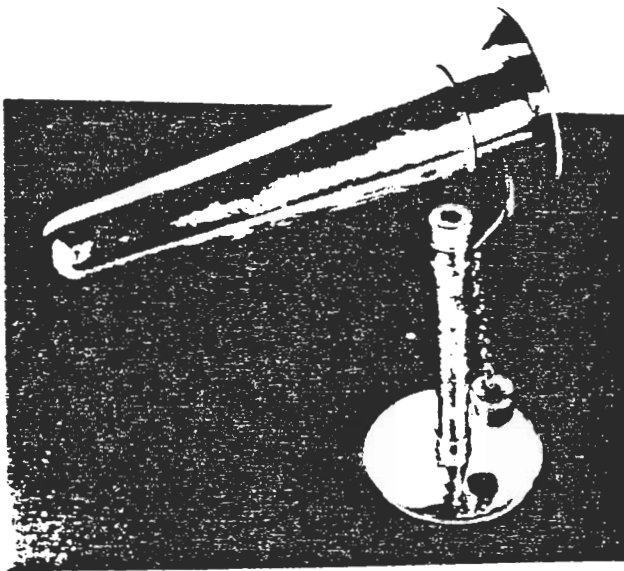

I think this is a:

From:

Please return to M. Donald Blaufox, M.D., Ph.D.

SEE NEXT PAGE

Item 1033A

OVARIOTOMY INSTRUMENTS, PESSARIES.

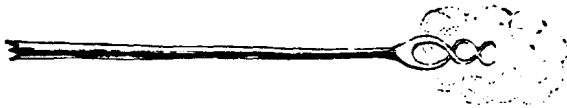

No. 1029A.

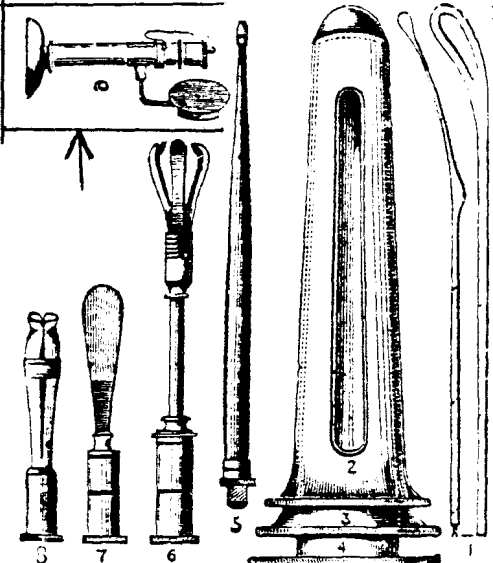

No. 1033A.

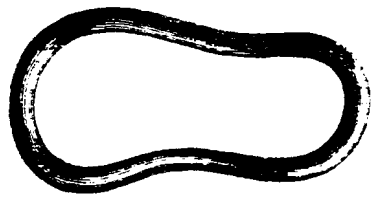

No. 1049.

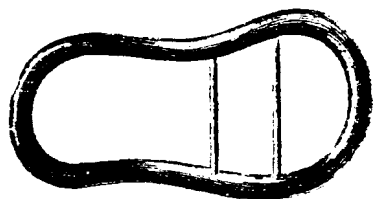

No. 1050.

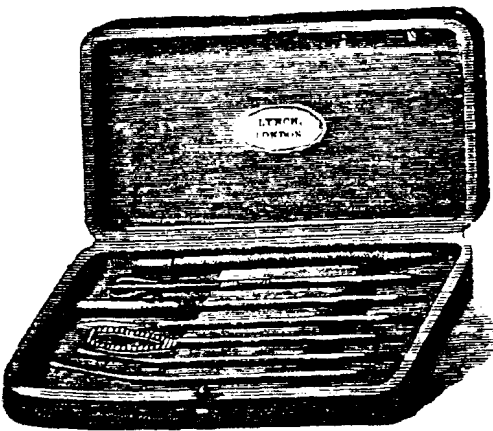

No. 1033B.



No. 1054A.

PART II.—SURGICAL INSTRUMENTS, ETC.

Prices subject to the Fluctuations of the Market.

No.	Ovariotomy Instruments, etc.,—continued.	£	s.	d.
1028	SPONGE TENT PROBE	0	5	9
1029	SYPHON DOUCHE, with long elastic tube, for injecting perchloride of iron, in post-partum hæmorrhage	0	9	9
1029A	TAMPON REMOVERS, with screw hook—(see Illustrations, page xxxi)	0	5	9
1030	TENTS of sea tangle	0	2	9
	TUBULAR NEEDLES,—			
1031	Curved right and left, for lacerated perinæum	0	6	0
1032	In plain ebony handles, as used by Brown, Sims, Boseman, and Simpson, for the wire ligature	0	4	0
1033	Ditto, in tortoiseshell handles	0	5	6
1033A	SET OF UTERINE INSTRUMENTS, in case, consisting of two electro-plated Speculums with Introductory Plug (figs. 2, 3, and 4); Uterine Curette and Sound (fig. 1); Porcupine Handle (fig. 5) on which can be screwed Sponge Holder, Scarifier, and Caustic Holder, (figs. 6, 7, and 8), and Candle Lamp with Reflector (fig. 9), very portable—(see Illustrations, page xxxi)	4	10	9
1033B	UTERINE CASE (Portable), containing Sound, Elevator, Playfair's Probe, Caustic Holder, Scarifying Lancet, and Sponge Holder, all fitting one handle, all strongly gilt to resist acid—(see Illustrations, page xxxi)	2	0	0
1034	UTERUS SCISSORS	0	10	0
1035	VAGINA DILATORS, electro-plated and gilt	0	19	0
1036	VULSELLUM, with rack adjustment	0	13	0
1036A	Ditto, curved with catch	0	9	6

PESSARIES.

BOXWOOD,—				
1037	Flat circular	per doz.	0	3 6
1038	Flat oval	"	0	6 6
1039	Globular	"	0	10 0
1040	Oviform	"	0	10 0
1041	CLAY'S GERMAN SILVER SPIRAL, fitted with Pelvis Band, etc.	each	0	13 6
1042	DUFFIN'S BOXWOOD AND IVORY	"	0	6 0
ELASTIC-GUM,—				
1043	Flat circular	per doz.	0	14 0
1044	Flat oval	"	0	14 0
1045	Globular	"	0	14 0
1046	Oviform	"	0	14 0
FOR ANTEVERSION, RETROVERSION, AND ANTEFLEXION OF THE UTERUS,—				
1046A	GREENHALGH'S	per doz.	0	10 6
1046B	Ditto, with bars	"	0	15 0

FOR ILLUSTRATIONS SEE END OF THIS PART.

CAN YOU IDENTIFY THIS

Material: Mixed composition.
Maker: Litter in Wein.
Presumed Use: OB-GYN.
Date: 1890-1910

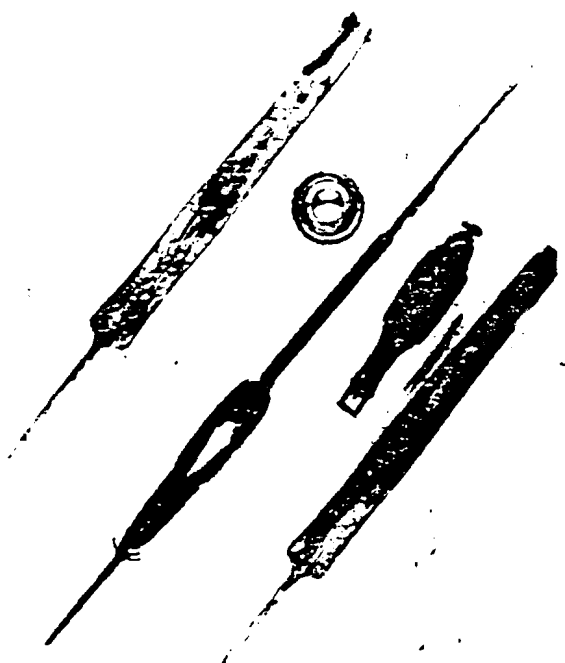

I think this is a:

From:

Please return to M. Donald Blaufox, M.D., Ph.D.

SEE NEXT PAGE

Item 973

Uterine and Vaginal Instruments, *continued*

FIG. 971.

FIG. 972. FIG. 973.

FIG. 974.

FIG. 975.

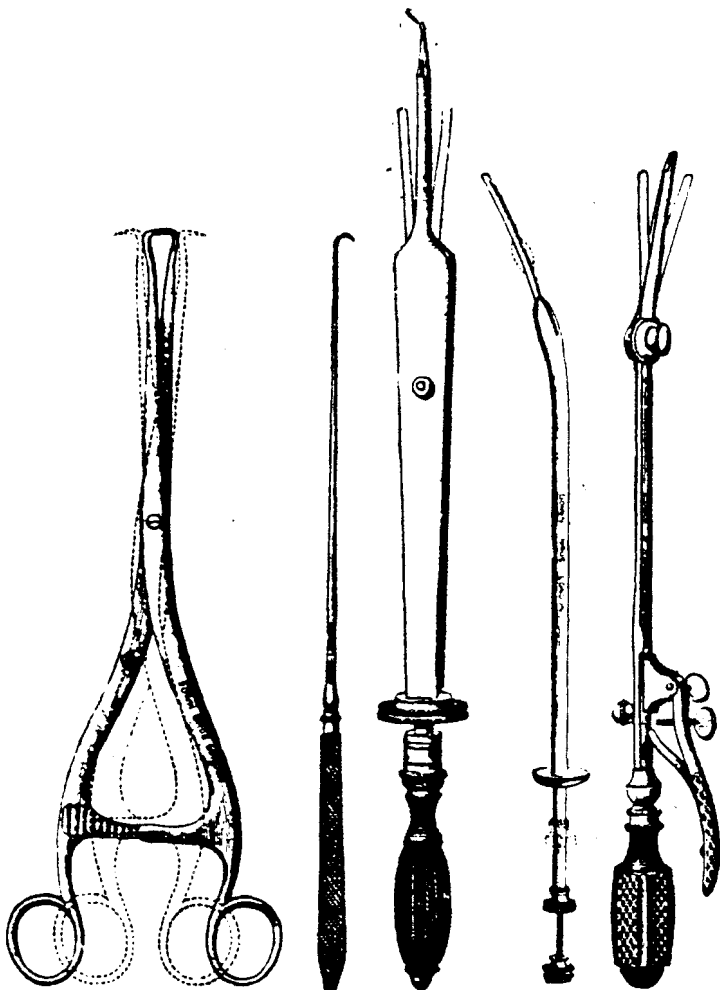
Instruments for Drawing Down the Cervix, *continued*,—

		£	s.	d.
Galabin's Forceps (<i>Fig. 971</i>)	each	0	13 6
Sims' ditto	"	0	9 6
Ditto, Fine Hook (<i>Fig. 972</i>)	"	0	4 6
Ditto, Double ditto	"	0	5 6

From: Down Bros. Catalogue - 1889

This is a:
 hysterotome
 (metrotome)



FOUNDED 1892

J. SKLAR MFG. CO., INC.
Surgical Instruments · Suction and Pressure Apparatus
38-04 WOODSIDE AVENUE, LONG ISLAND CITY, N.Y. 11101

AREA CODE 212 429 1900

CABLE ADDRESS
SKLARCO NEWYORK

May 31, 1984

Dr. M. Donald Blaufox
Chairman, Dept. of Nuclear Medicine
Albert Einstein College of Medicine
1300 Morris Park Avenue
Bronx, N.Y. 10461

Dear Donald:

When I returned to the office from a recent business trip abroad I found your letter of May 14th waiting for me. As a matter of fact I do remember you well from the times that we met at Sue and Al's home.

With regard to the picture of the Sklar instrument that you sent me, it looks like the brace from one of our Cushing Cranial Drills. According to what I could determine from the old Sklar catalogs we have on hand here, this instrument became part of our line in the 1920's. We discontinued it sometime between 1977 and 1982. To the best of my knowledge the style of this brace did not change during that time, and so it would be hard to say exactly how old your particular one is.

In answer to your question, the J. Sklar Mfg. Co., Inc. itself was founded in 1892, and, from the beginning, it was always in the surgical instrument business. Unfortunately, except for our reference copies, we do not have on hand any extra old catalogs.

I hope that the above information will be of at least some assistance to you, but if you have any further questions, please don't hesitate to give me a call. Good luck with your collection!

Sincerely

John Sklar

JS:gn

P.S. I am returning your photograph to you and enclosing a page from our 1977 catalog illustrating the Cushing Drill, with this letter.

From the 19th Edition of our Sklar Catalog (printed in 1977). This was the last Sklar catalog to show the Cushing drill.

45-2635
45-2636

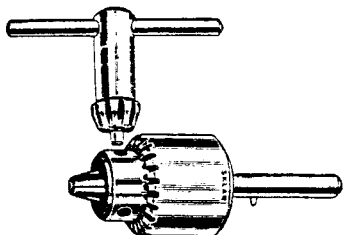

45-2645
45-2648
45-2651
45-2652
45-2661
45-2662

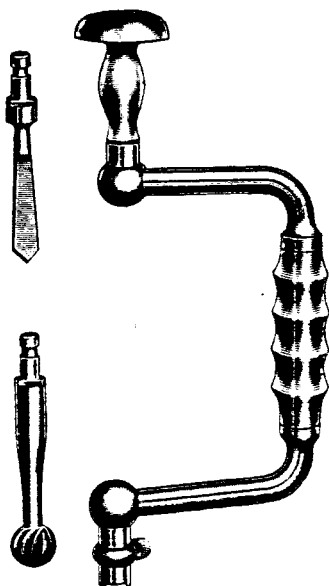

45-2665
45-2710
45-2714
45-2718
45-2725
45-2730

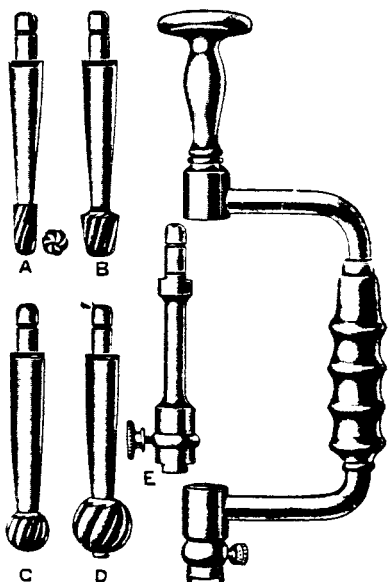

QUALITY
SURGICAL
INSTRUMENTS

bone and cranial drills

45-2635 JACOBS Chuck with adaptor for Stille-Sherman and Stille Bone Drill, accommodating drill points up to $\frac{5}{32}$ " (4 mm) diameter.

45-2636 Accommodating drill points up to $\frac{1}{4}$ " (6.4 mm) diameter.

CUSHING

45-2645 Cranial Drill, 9" (22.9 cm) long, complete with one drill 2 cm. and one burr 2 cm. diameter Drill and Burr Not Plated. Brace Stainless Steel.

45-2648 Brace only, for Cushing or Hudson Drill Set.

45-2651 Burr Only 1 cm. Carbon Steel.

45-2652 Burr Only 2 cm. Carbon Steel.

45-2661 Flat Drill only 1 cm. Carbon Steel.

45-2662 Flat Drill only 2 cm. Carbon Steel.

HUDSON

45-2665 Cranial Drill, 9" (22.9 cm) long, complete with 4 burrs.

Cerebellar attachment and brace Stainless Steel, complete in case.

45-2710 Burr Only A-10 mm. Carbon Steel.

45-2714 Burr Only B-14 mm. Carbon Steel.

45-2718 Burr Only C-18 mm. Carbon Steel.

45-2725 Burr Only D-25 mm. Carbon Steel.

45-2730 Cerebellar attachment.
(Fig. E)

Dear Customer,

So that we can respond to your correspondence more promptly, we are taking the liberty of replying to your letter by making a marginal notation on the letter itself.

The volume of mail which we receive would make it impossible for us to reply to your letter the same day, if we adhere to the conventional procedure of typing a formal answer.

Please understand that in replying to your inquiry in this informal way, we feel that a proper response is far more important to you at this time than formality. Should you find it necessary to write again, please return this letter.

Thank you,
DISSTON, INC. - Danville, Va.

JOHN J. RICHARDSON, D. P. M.
56 SEVENTH AVENUE
NEW YORK, NEW YORK 10011

Telephone 212 - 675-7591

January 9, 1986

Company Historian
Consumer Relations
The Disston Company
Danville, Virginia 24540

Dear Sirs,

I am a collector of Medical Antiques and recently came upon an instrument that I can not identify in any of the literature available to me. I am hoping you can aid me in identifying the instruments as to approximate date of manufacture and usage.

I have included a picture of only two of the instruments but the third is similar and carries the DISSTON manufacture markings. The two included in the picture carry the STILLMAN and BOKER manufacture names respectively.

Each of the instruments measures between 16 and 17 inches long. One side of the blade is sharp for cutting while the other side is that of a saw. The instruments are reputed to be "For Field Use" amputation instruments issued to Union and or Confederate troops during the Civil War. Having an "all in one" instrument was to allow for the expeditious amputation of a limb.

Any help you can afford me in the identification will be deeply appreciated.

Sincerely,

John J. Richardson, D.P.M.

John J. Richardson, D.P.M.

JJR/imp enc 1-13-86

The last catalog this item appeared in was 1914 - a reprint addition. The saw or knife was in the Butcher saw family.

Thank you
S. Asher

DE-HORNING, No. 6

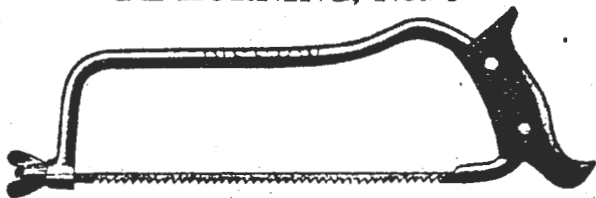

Japanned Malleable Iron Frame, Beech Handle, complete, with Blade 10 inches long, 1/4-inch wide.
 No. 6. Complete,.....\$7.00 per dozen; Blades only,.....\$1.30 per dozen.
 Packed half dozen in box.

**SAW KNIVES
 CRUCIBLE STEEL BLADE**



Disston,.....\$4.30 per dozen. Keystone,.....\$3.45 per dozen.
 Packed one dozen in box.

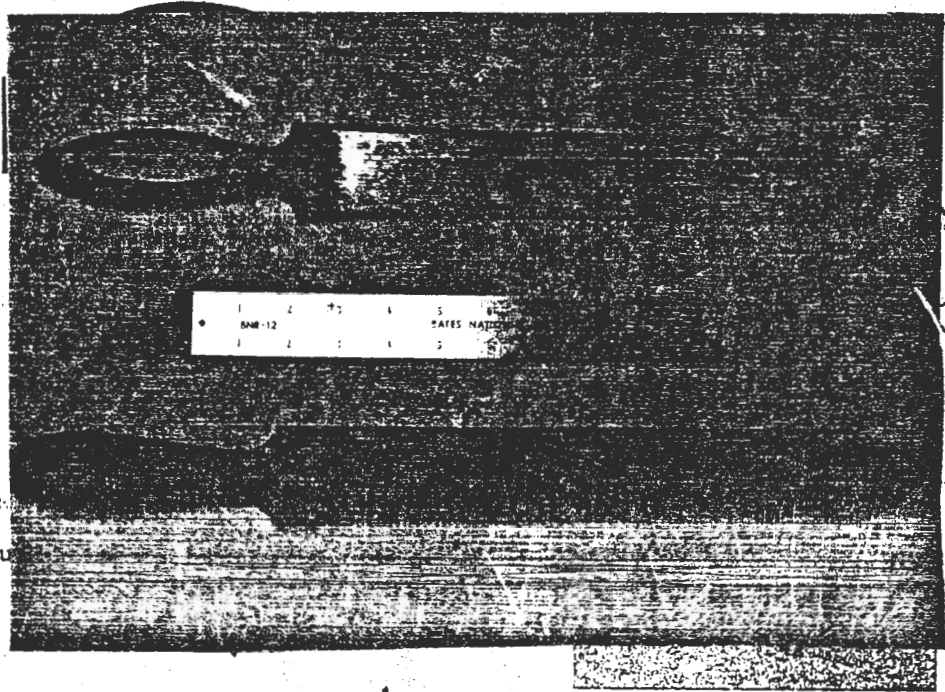

Buy

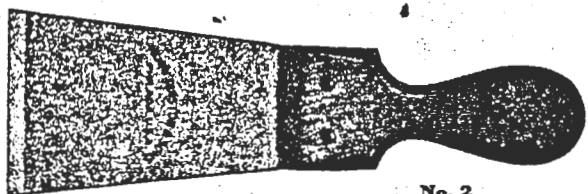

No. 2

WALL SCRAPERS

- No. Per doz.
1. Cast steel, 3 ins. wide, \$1.50
 2. Cast steel, 4 ins. wide, \$1.70
 6. Special, 4 ins. wide, \$1.05
- Packed one dozen in box.



Historical Images of the Drug Market—V

by William H. Helfand

THE handsome trade card for T. Smith, wholesale and retail chemist and druggist in Boston, England, was engraved in London in the early part of the 19th century. Despite its small size, a great deal of information is included. For example, at the foot of the figure of the sage who is pointing to some distilling apparatus, a medicine chest, a mortar and pestle, an alembic, and an artist's palette are clearly drawn. The types of prod-

uct carried in the inventory of the pharmacy are also noted. The engraver saw fit to include a variety of type faces to attract attention. Smith's card is similar to the standard tradesman's card used before the advent of commercial lithography in the late 1820s, but is more interesting than most because of the extensive information incorporated in so small a size. (Size of trade card - 3 x 4 7/16 inches. Original in W. H. Helfand collection.)

These Radium Rays

have proved highly valuable in the treatment of the following conditions:

Anemia
 Arteriosclerosis
 Arthritis
 Catarrhal conditions
 Diabetes
 Dental conditions
 General debility
 Goitre
 High blood pressure
 Menopause and
 Menstrual disorders
 Nephritis
 Neuralgia
 Neurasthenia
 Neuritis
 Nervous conditions
 Obesity
 Prostatitis
 Rheumatism
 Senility
 Sexual conditions
 Skin disorders

RADITHOR—PERPETUAL SUNSHINE



Radithor—Perpetual Sunshine
 Exact Size

JUST a tiny bottle of apparently lifeless, colorless and tasteless water is all that the eye can see or the tongue can detect, yet in this bottle there reposes the greatest therapeutic force known to mankind—radioactivity.

This Spot Contains RADIUM

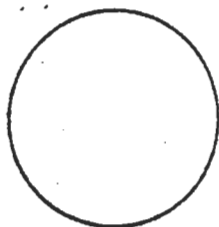

Millions of Radium Rays arise from this little spot constantly.

You can actually see these rays through the lens on cover.

How to See the Rays

TAKE this booklet into a dark room at night. After 15 minutes open cover about two inches, placing lens close to your eye, and focus on spot. You will then see rays arise from the spot like a continuous shower of shooting stars.

One may look at this little spot every night for months, or years, or even centuries—and the same steady flow of rays will arise with only slight decrease. It will be 20,000 years before the radium on this spot ceases to produce rays.

RADITHOR Perpetual Sunshine

THE radioactive water that produces the perpetual sunshine we have described is known as Radithor. It is a combination of actual radium and mesothorium scientifically incorporated with pure triple-distilled water. By merely drinking Radithor, the radioactive elements are distributed throughout the whole body where they shower their billions of rays on the cells to stimulate their function. And so, as the cause of most abnormal physical conditions is internal, when this simple means of putting rays in the body was developed, modern therapy took a great stride forward.

On the spot in the front of this book there is about one drop of Radithor. The yellow material on the spot is zinc sulphide which permits the ray effects of radium and mesothorium to be seen at night. The bright glow from the spot after exposure to light is not due to the radium. This glow dims in a short time. The actual rays cannot be seen until the bright glow fades; then the rays are visible, but only through the lens on the cover.

The rays you see on the spot all come from the single drop of Radithor. The same action you see there—the same continuous flow of rays—takes place in every cell throughout the body after a course in Radithor is started.

Thus Radithor is not a drug. It is not a medicine—but a physical means of re-energizing weak and inactive cells with millions of rays. It is this continuous application of rays to the cells by means of Radithor that has proved a revelation in treating conditions where drugs have been of no avail.

UNITED STATES PATENT OFFICE.

CHARLES A. TATUM, OF NEW YORK, N. Y., ASSIGNOR TO WHITALL, TATUM & CO., OF SAME PLACE.

TABLET-MACHINE.

SPECIFICATION forming part of Letters Patent No. 841,805, dated July 9, 1895.

Application filed February 8, 1895. Serial No. 837,518. (No model.)

To all whom it may concern:

Be it known that I, CHARLES A. TATUM, a resident of the city, county, and State of New York, have invented certain new and useful
5 Improvements in Tablet-Machines, of which the following is a specification.

My invention relates to tablet machines, and has for its object to produce a simple, cheap and efficient machine for making tablets wherein the plungers can be removed
10 and replaced at will and the capacity of the mold regulated by adjustment of the die to suit the various sized tablets it may be desired to mold.

To this end my invention consists in the construction and arrangement of devices herein-
15 after set forth and claimed.

My invention will be understood by reference to the accompanying drawings, where-
20 in—

Figure 1 is a front elevation of a tablet machine embodying my invention. Fig. 2 is a similar view of the same, taken at right angles to the view illustrated in Fig. 1, with parts
25 broken away.

In the drawings, A indicates a suitable standard. This standard rests upon a base B and is provided with a guide *a* for the upper plunger. The standard is also provided with a receiving table C for the powder, and a removable die *b* which is mounted in the table and held in position in any suitable manner, such as by means of a set-screw *c*. This table can be vertically adjusted by suitable means, such as by guides *d* and set-
35 screws *e* which enter slots *f* in the standard A. The base B is apertured for the reception of a sliding rod *h* which is provided with a slotted sleeve *i*, into which sleeve the counter
40 or lower plunger *j* is entered and secured in place, as by a set-screw *k*. This counter enters the die *b* for purposes which will be hereinafter more fully described.

Journalled upon a pin *l* upon the standard
45 A is a handle D which passes through the slot in the sleeve *i*. An upper plunger *m* works in the guide *a* and may be operated by any suitable means, as by the pivoted handle E and link *n* pivoted eccentrically to a disk *o*
50 carried by the handle E. The plunger *m* is

preferably removably secured in the operating means so that it may be replaced by a plunger of different size and formation. The handle D may, if desired, be connected with the handle E of the lower plunger or counter
55 *j* in any suitable manner.

It is obvious that a vertical adjustment of the table C with relation to the lower plunger or counter *j* will operate to regulate the depth
60 of the mold.

If it is desired to make tablets of different dimensions and configuration from that for which the machine is set, it is merely necessary to replace the plungers and die with
65 those of the desired size and formation.

The operation of my improved machine is as follows: The machine having been set with plungers and a die of the desired size and formation and the platform having been adjusted to give the proper predetermined depth
70 for the mold, the powder is poured therein and the plunger *m* is brought down into the mold by the handle E to compact the powder into a tablet. When the tablet has been formed, the plunger is raised out of the die and the
75 handle D is operated to eject the tablet from the mold.

Now while I have shown and described one form of my invention, I would have it understood that I do not mean to thereby limit myself to the particular arrangement and construction of parts herein shown, as the parts, their construction and arrangement may be varied without departing from the spirit of
80 my invention.

What I claim, and desire to secure by Letters Patent, is—

In a tablet machine, the combination of a plunger or counter, a table C carrying a die into which the counter is entered, a slotted
90 standard A, set-screws *e* serving to enter the slots and to secure the table C in its adjusted position, and a plunger entering the die and co-operating with the die and counter, substantially as described.

CHARLES A. TATUM.

Witnesses:

GEO. E. MOBER,
CHARLES E. SMITH.

5
4
1
8
9
5

(No Model.)

C. A. TATUM.
TABLET MACHINE.

No. 541,895.

Patented July 2, 1895.

Fig. 1

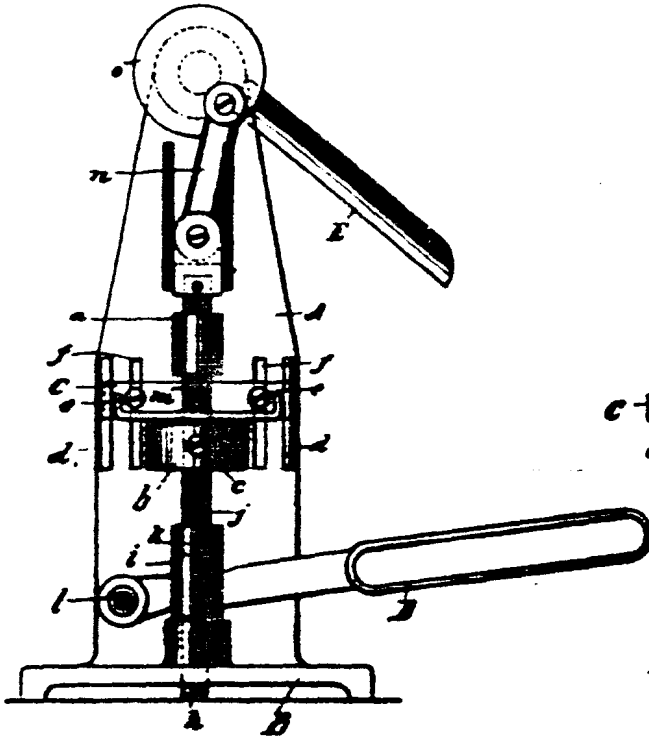
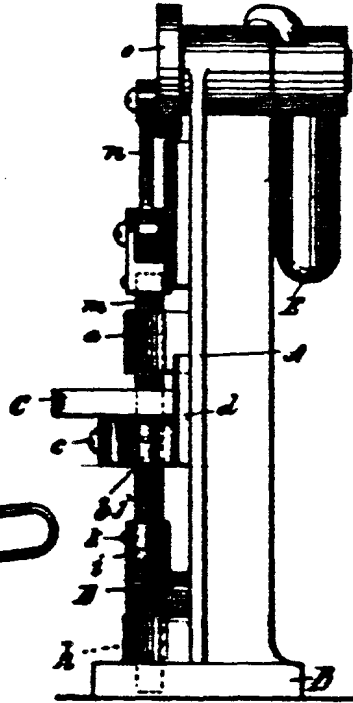

Fig. 2



WITNESSES:

Charles A. Tatum
Charles A. Smith

INVENTOR

Charles A. Tatum,
BY
Almon A. Smith
ATTORNEYS.

541895

His hobby fills museums

A CURATOR OF EARLY CURES

By Ted Schwarz, Contributing Editor

The ivory doll that rests near the desk of Phoenix, Arizona, gastroenterologist Robert Kravetz, MD, is a flawlessly carved miniature of a well-endowed naked woman. It looks a little like what might be an expensive premium offered for taking out a lifetime subscription to a men's magazine.

In reality, it's a Chinese doctor's doll, an essential part of ancient Chinese gynecology. The doll was used as a patient surrogate, since doctors were prohibited from examining the woman's body. "The husband would come alone to see the doctor," Dr. Kravetz explained. "He would describe the patient's symptoms, pointing to the place on the doll where she was having difficulty. The doctor would make his diagnosis from what the husband described on the doll."

Window to the past

Unusual medical practices were by no means confined to the Chinese. In the medical museum Dr. Kravetz has established in Phoenix Baptist Hospital's lobby, you

can find digitalis tea bags used for patients with heart problems. The patient would brew the tea, then drink it in order to correct heart problems. "The tea was probably effective," Dr. Kravetz explained. "You just couldn't give a consistent dosage."

The museum also holds such items as *Mrs. Dinsmore's Cough And Croup Balsam Of Horehound And Anise*; *Warner's Safe Cure for Kidney and Liver, Bright's Disease, Urinary Disorders, Female Complaints, General Debility and Malaise*; a 19th century enema set; and a tin suppository mold from the 1860s.

Many of the patent medicines contained opium and alcohol, substances that would not cure the patients, but certainly made them feel better about ill health.

Modest beginning

The 51-year-old Dr. Kravetz, former chief of medicine for Phoenix Baptist Hospital and a member of its active teaching staff, has maintained an interest in the history of medicine for the past 15 years. He began by collecting antiques, then obtained a few patent medicine bottles in a flea market for display in his office.

In 1970, Dr. Kravetz and his



Ted Schwarz is the author of more than 50 books—most recently the autobiography of John DeLorean, on which he collaborated.

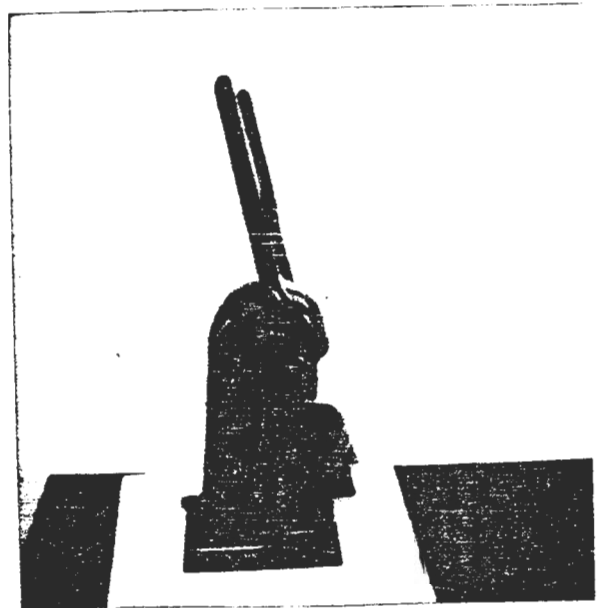
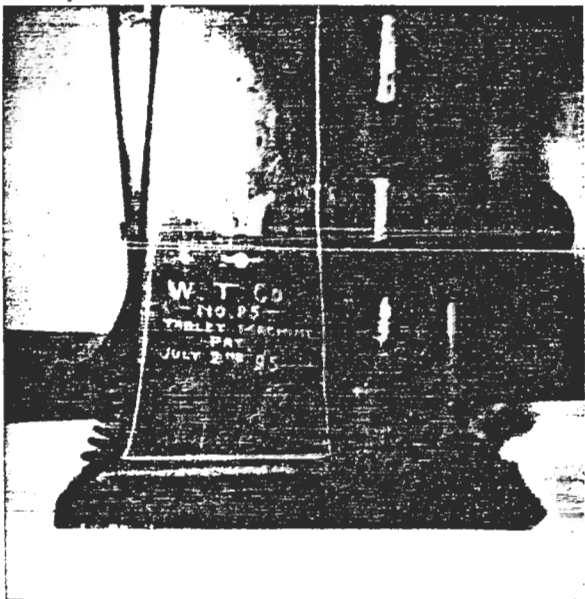
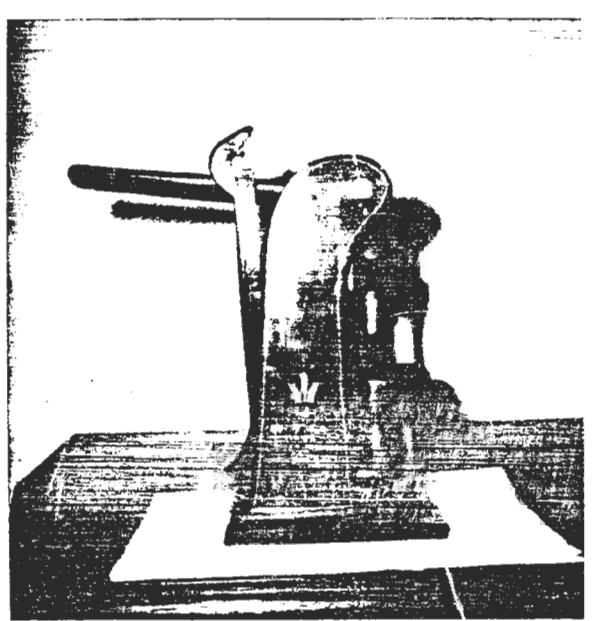
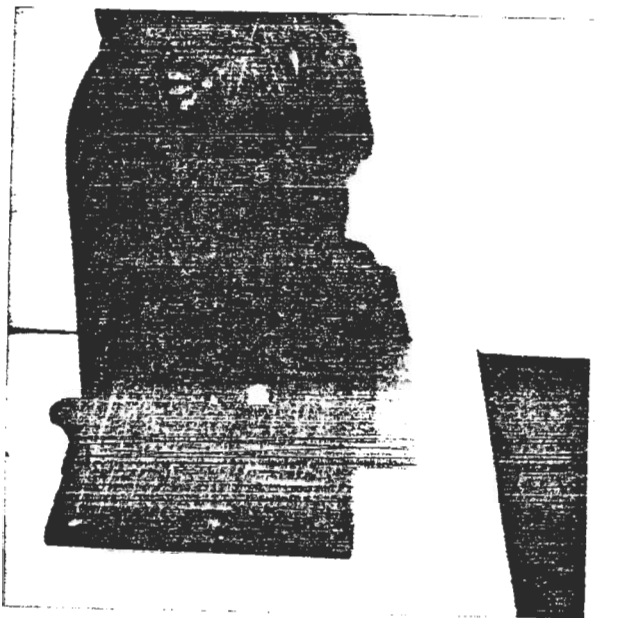



Above: Dr. Kravetz places a large Wedgwood mortar and pestle into a display case.

Left: The bottles of poison that Dr. Kravetz holds will soon be added to the displays in his hospital lobby museum.

wife, Nancy, were visiting Newbury Port, Massachusetts, a town north of Boston that dates back to the 1600s. He stopped by the local hospital, asking if there were any old drugs available. The staff had nothing available, but mentioned that there was a nearby drugstore that had opened in 1845 and might have some of the old stock.

"There had only been three druggists in the store's 132 years, and they had been saving things in a loft," Kravetz explained, his voice still holding some of the excitement he felt at the time of his discovery. "It was like walking into the past. There was a 15' X 35' loft room packed with old

drugs, bottles, and equipment. I spent all day looking through what was there. The owner wanted to sell everything, and I decided to buy it all." When it was shipped to Dr. Kravetz, he found he had acquired 6,000 pounds of medical history.

Dr. Kravetz was introduced to a world of which he had only been vaguely aware. He discovered herbal medicine, including herbal digitalis that was popular 200 years ago. There were hand-blown apothecary jars, glass containers, jars for herbs and spices, and scales and holders for all types of needs.

Because the cost of shipping was greater than the price for the

Right: This 19th century American surgical instrument set fits exactly into the original velvet-lined rosewood case made for it. Note the ivory handles on the instruments.

Bottom: These obstetrical forceps, although quite similar in design to modern ones, were actually made in the mid-19th century.

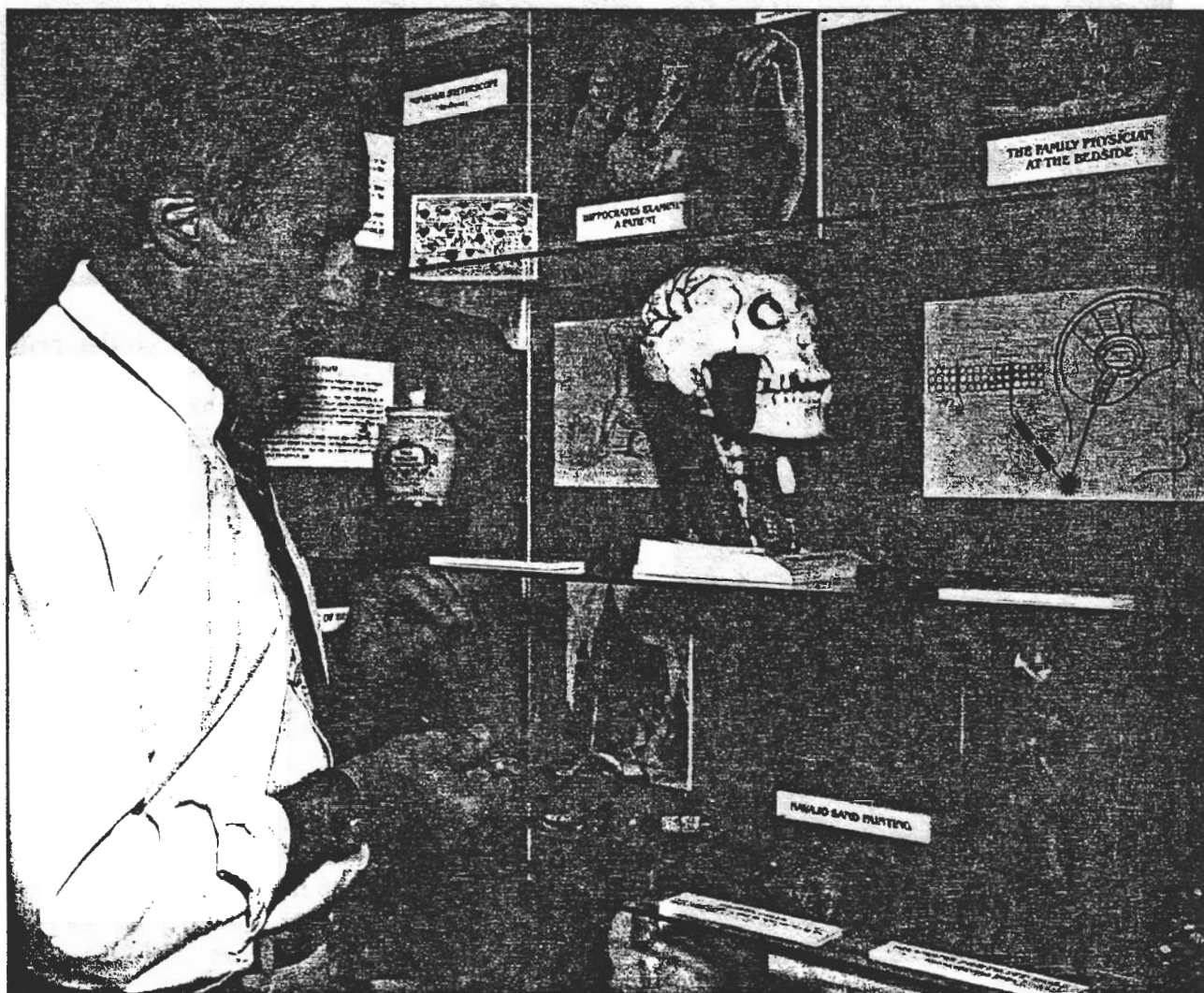
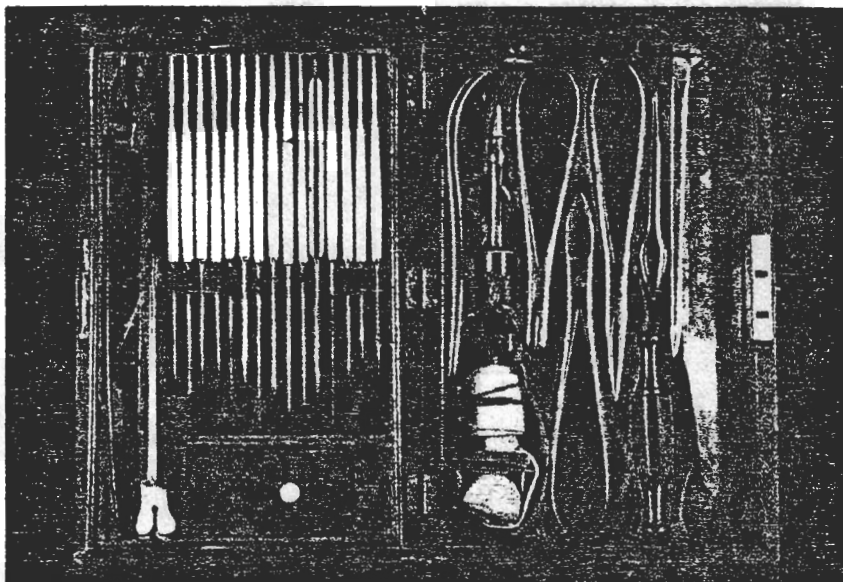

merchandise, Dr. Kravetz decided to open the Antique Apothecary Shop. His father, a retired businessman, took over the chore of running the business for the next year. Although sales were not great, the store did break even by the time the lease was up, and a restaurant took over the location.

Lobby museums

With his collection becoming more than a hobby, Dr. Kravetz became fascinated by the history of medicine and wanted to acquire items dating back thousands of years. While maintaining his office display, he also established a small showcase at Good Samaritan Hospital in Phoenix.

When Dr. Kravetz moved to Phoenix Baptist Hospital, the administration there decided to include a full lobby museum as part of the hospital's renovation plan. That museum opened in 1978 and was followed soon after by a museum at the Bullhead Community Hospital in Bullhead City, Arizona. A third museum, which Dr. Kravetz is now planning, will be housed in a mall connecting a retirement home with a nursing facility. That museum will be a replica of an 1890s drugstore and will feature medicines used in the Arizona Territory. Each museum has numerous cases whose contents are regularly changed.

Today, Dr. Kravetz's collection reflects the unusual history of

modern medicine. "It always amazes me how little we've advanced in medicine," he explains, pointing to a set of urological instruments dating back 2,000 years. The instrument design is so similar to modern equipment that they could be sterilized and used

"It always amazes me how little we have advanced in medicine."

in procedures today, and the doctor would not be uncomfortable with the equipment.

"The delivery forceps for babies are from a pattern developed by the Chamberlin family in the 1600s. They have been refined, but they're basically the same," he said.

One decorated English ceramic 4-quart jar for leeches is testament to the old belief that bloodletting was a cure-all. "Bleeding goes back at least 2,000 years. There were sets of bleeding bowls marked with the amount of blood to be removed according to the illness encountered," Dr. Kravetz explains. "George Washington was bled to death in an effort to cure him. Bleeding, purging, or vomiting were the common treatments for many ailments."

He added that even in the 1950s, when he was in the New York University College of Medicine, bleeding was used for con-

gestive heart failure. "When a patient had polycythemia, bleeding was considered beneficial. Leeches are still used for some forms of microsurgery today."

An endless quest

Dr. Kravetz has traveled extensively, always seeking objects from medicine's history. During a 1984 trip, he found an 1850s medical instrument in a flea market in Paris. Other journeys have taken him to the Orient, South America, the Middle East, Scandinavia, and numerous other parts of the world. "Early American medicine evolved from European practice," he said. "There was great similarity among English, French, and US medicine."

One of the prize possessions in the collection is a Revolutionary War medicine chest of the type owned by Dr. Benjamin Rush. In addition to being a physician and surgeon, Dr. Rush was involved with the creation of the United States Mint and a signer of the Declaration of Independence. The medicine chest includes all the materials needed to function as pharmacist, physician, and surgeon, the full range of the revolutionary-era doctor—extracts, powders, a scale, mortar and pestle, mixing devices, and surgical instruments.

"Prior to 1850, amputation was the treatment for most injuries. Since there was no anesthetic, a surgeon's skill was determined by his speed. All the instruments were meant for speed. Whiskey

was given as an anesthetic, and there was frequent loss of life from traumatic shock. This is where the term 'bite the bullet' came from. The patient would

literally be given a bullet to bite during the amputation."

The museum contains a number of early saws, ranging from small finger saws to larger instru-

ments used for skulls. From the ancient Incas come trephining tools, which were used to open a small hole in the skull in order to remove a bone fragment and re-

COLLECTING MEDICAL MEMORABILIA: WHAT YOU SHOULD KNOW

If you are interested in becoming a medical collector, Dr. Robert Kravetz has some advice.

"Most collectors start by obtaining everything they can, then becoming selective," Dr. Kravetz explains. "They look for quality and superior one-of-a-kind items." An example would be a Pharmaceutical Show Globe. Used frequently in the 1840s, there was only one globe per store. "This is quite different from old bottles with glass labels, which are much more common. There might have been 300 in a store that had only one Show Globe," he said, explaining that the current price for a Show Globe is at least \$280.

Leech jars are another example. Again, there was only one per store, and many were broken over the years. Today they sell for \$500 to \$1,000. "This represents an increase of 200 to 300% since I started collecting," Dr. Kravetz said.

"Most people mistake age for rarity and value," said Dr. Kravetz. "They see medical instruments from the 1920s and 1930s and realize that they're 50 or more years old. They think the instruments must be valuable and spend a fortune for them. These are so common that they're worth a few dollars at the most. Spending \$25 for a box of them is probably too much.

"The valuable instruments are from the 19th century and earlier. Most of these were made in England and France until the 1850s, when they began to be made here. The European craftsmen would sign their instruments. Even the most common set from this period is likely to be worth \$1,500 in superb condition," he said.

Dr. Kravetz also suggests seeking cases of pre-Civil War surgical instruments. "All doctors per-

formed surgery back then. General surgery was a necessity, and the faster you worked, the better your reputation. Many of the sets came in wood and brass boxes with velvet liners. If you find some instruments out of place, they're not from the original set. Each instrument was originally designed to fit exactly," he explained.

Rather than buying from other collectors, Dr. Kravetz says that it is possible to find instruments in the same manner that he has. "Flea markets are a good source, and the prices are often lower than what a collector will pay. You may find some at auctions, and your patients may give you things when they discover what you collect. A lot of my collection has been donated by my patients who had a pharmacist or doctor relative years ago, and they never got rid of his supplies," he explains.

Medical artifact prospecting is better on the east coast. "You'll have more success with older cities, especially along the east coast," he said. Often there will be a pharmacy that has existed for more than a century. Many of the older items have been stored rather than thrown away. Questioning the current owner can lead to some collectible and quite valuable items.

The largest association for medical collectors is the Medical Collectors Association, started by Dr. M. Donald Blaufox (Mayer Bldg., Rm. 324, 1300 Morris Park Ave., Bronx, New York, 10461). There are also some standard references including: *Antique Medical Instruments* by Elizabeth Bennion (Sotheby Parke Bernet and University of California Press, Publishers); and *Civil War Medical Instruments and Equipment* by Dr. Gordon Dammann (Pictorial Histories Publishing Co. of Missoula, Montana).

duce pressure. Trephining was the earliest form of neurosurgery, and all medicine kits contained the essential tools.

Early quacks

Part of the museum holdings include medical quackery items, such as patent medicines that contained alcohol or opiates, devices that used electric current at a time when people did not understand electricity, ultraviolet light devices, and similar gadgets. There are magnetic necklaces to ease teething pain, and colored lights that, when played over the body, "cured" arthritis.

"*Collier's Magazine* did a study of the problem at the turn of the century that helped lead to the 1906 Pure Food And Drug Act to stop the quackery."

Dr. Kravetz also has collected medical texts dating back to the 1700s from medical schools in New York, New England, and Philadelphia. "The disease descriptions are accurate and done well," he said.

His search for authenticity, and the vast knowledge he has acquired, have given him the opportunity to work with museums not only in Arizona, but throughout the United States. He has dealt with the Smithsonian and the Armed Forces Institute as well as numerous historical societies.

Priceless collection

The value of Dr. Kravetz's collection is difficult to determine.

Although the Medical Collectors Association is quite small, some of the collected items cross over into other areas of interest. For example, certain medical bottles were blown in such a way that there are ridges in the surface of the glass. These were designed to enable patients to reach for them in the dark and be able to differentiate among items that might otherwise be harmful. These are as avidly collected by bottle enthusiasts as they are by medical collectors.

Since the Phoenix Baptist Hospital museum is open 24 hours a day, 7 days a week, it receives a great number of visitors. Often these visitors become the source of more "finds." Dr. Kravetz has received such donations as an old-fashioned dentist's drill powered by a foot pedal and old blood pressure cuffs.

All donations to the museum are actively encouraged, and displays are regularly rotated so that each category and item can be carefully researched and displayed.

As the collection of more than 2,000 items keeps growing, Dr. Kravetz is anticipating the day he will have either a larger chain of museums or one large medical museum complex.

Although his first commitment will always be to the practice of medicine, Dr. Kravetz has found a hobby that both enhances and enriches his professional life. ■

Antiques & Advances in Medical Instruments: Some Medical, Surgical and Quack Apparatus

By Joyce McCarthy

Sometimes we lose sight of how lucky we are to live in the 20th century with all the advances in medical treatment and equipment available. This awareness becomes particularly apparent when viewing medical apparatus used during the 19th century.

Dr. Terry Hambrecht of NINCDS collects medical, surgical, and quack devices used during the 19th and early 20th centuries. He owns over 100 individual items, the earliest an 1830 tooth extractor. This long ebony-handled device has a curved hook on its end that was placed against the outside of the bad tooth and turned at a sharp angle against the jaw to pull out the tooth. Occasionally jaws were broken by the pressure exerted.

Historical Instruments

Many of these historical instruments have designs which are forerunners of ones used today. Many others haven't changed much, especially those used for orthopedic surgery. But the old devices often reflected new knowledge learned at that time in history.

Medical men were just beginning to learn how the nervous system worked in the years 1770 to 1800. That was when they first

with electricity.

Dr. Hambrecht, head of the Neural Prosthesis Program in the NINCDS Fundamental Neurosciences Program, became interested in historical medical devices, particularly those used in electrotherapy, while tracing the origin and development of ideas behind modern neural stimulating devices used in diagnosing and treating the neurologically handicapped.

Neural Prostheses Research

He has directed research which has led to development of safe and effective stimulation techniques and electrodes. The results of this research are now being applied to practical neural (nerve) prostheses such as the cochlear implant for "sensory deaf" individuals.

In this device, stimulating electrodes are placed in the cochlear (inner ear) and bypass the lost transducers which convert acoustic signals in the ear to electrical signals in the auditory nerve. The auditory nerve fibers convey the electrical signals directly to the brain where they are interpreted as sensations of sound.

One electrotherapeutic device in Dr. Hambrecht's collection is "Davis and Kidder's Parent Magneto Electric Machine for Nervous Diseases" dated about 1860. It claimed to be able to relieve neuralgia and most other neurological disorders. Metal cylinders attached to a hand-cranked generator delivered an electric current to the affected area. The amount of current depended upon how fast the generator was cranked. Holding on to the cylinders, you get something like a modern-day electric shock.



Dr. Hambrecht of NINCDS holds an ivory-handled surgery kit which was used for amputations.

Vaccinating Instruments

Vaccinating instruments "represent one of the first practical treatments based on the development of an immune reaction," Dr. Hambrecht said. This concept was applied by Edward Jenner in 1796 to inoculate a boy against smallpox.

He transferred part of a scab which contained live virus from a milkmaid who had cowpox. Six weeks later he injected smallpox virus into the body and fortunately the immunization proved successful.

The Civil War lasted from 1861 to 1865 and mass vaccinations against smallpox were conducted; even so there were still isolated epidemics of the disease. Many types of vaccinating devices were used but an ingenious type was the spring-loaded version (see picture) that snapped the vaccine into the arm.

Bloodletting had its heyday about 1830. There were a multitude of different types of instruments designed specifically to relieve sick

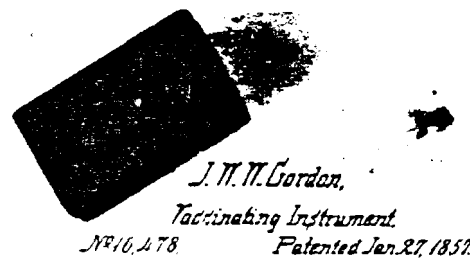

Dr. Hambrecht owns a vaccinating kit and the original patent dating from 1857.

and healthy people of blood and to reduce the demand for leeches. The fold-up fleam usually had blades of different sizes and was used manually like a lancet to puncture the skin or a vein. Manual bleeders date back to Hippocrates (5th century B.C.).

The spring lancet invented in 1719 permitted the operator to inject the blade without exerting manual pressure. The scarificator, a multiblade version which was often used with a glass cup, introduced efficiency and reduced the messiness of earlier bleeders.

Theory of Bloodletting

Bloodletting was believed to rid the patient of an overabundance of harmful body humors. It was widely practiced throughout the world and was often done on patients until they were weak. Used less and less, the practice was almost abandoned by the end of the 19th century because it was eventually considered ineffective.

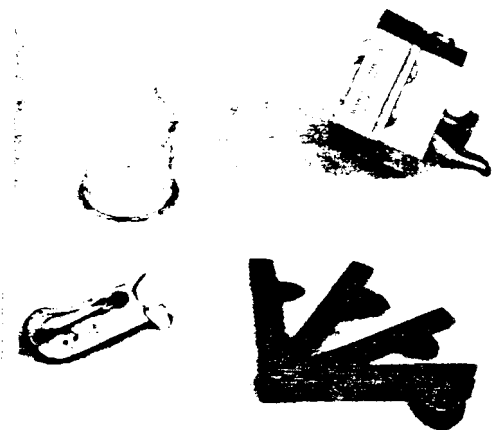

Bloodletting devices had their heyday about 1830. Shown (bottom, l to r): the spring lancet, the fold-up fleam, the scarificator and glass cup.

But it is still used in certain blood and cardiorespiratory disorders under the less heroic title—phlebotomy.

The microbe theory was first accepted in the 19th century. At that time, most surgical instruments had handles made of ivory or ebony. But the knowledge that bacteria and other microorganisms caused many diseases brought about the change to sterilizable all-metal instruments by the end of the 19th century.

ANTIQUE MEDICAL INSTRUMENT COLLECTION

(Continued from Page 1)

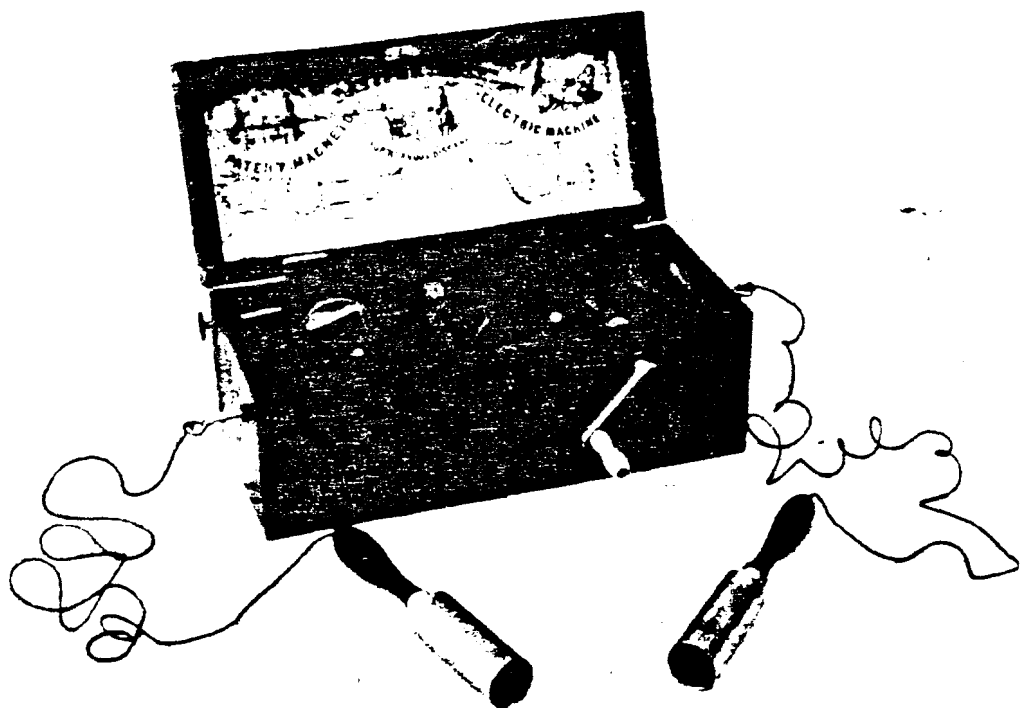

"Davis and Kidder's Patent Magneto Electric Machine for Nervous Diseases" was claimed to be "endorsed and used by the Leading Physicians throughout the United States and Europe."

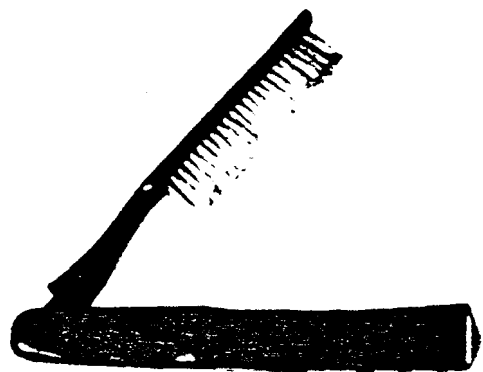

A wooden toothbrush used during the Civil War was carried efficiently in a compact holder with its own drainholes on the underside.

Dr. Hambrecht is shown (see picture) with a 19th century ivory-handled surgery kit which was used for amputations.

Anesthesia was also developed in the 19th century. Doctors during the Civil War used chloroform or ether, but ether was dangerous at night because it caught fire easily. The "bite the bullet" expression originated in the days before anesthesia when wounded soldiers were literally given lead bullets to bite during surgical operations.

The status of medical theory and treatment changed rapidly after the Civil War. This was principally due to the relatively new microscope, the microbe theory and the acceptance of the scientific method of devising a hypothesis and checking it experimentally.

Sources of Antique Instruments

Dr. Hambrecht finds most of the items for his collection at flea markets and antique shows. He hunts for them on weekend travels in Maryland, Virginia, and West Virginia. However, many such articles can be found around areas where the big medical centers were located in the 19th century: the University of Pennsylvania and Jefferson Medical College in Philadelphia; the New York Hospital Medical School in New York City, and Massachusetts General Hospital in Boston.

He has also received some of his collection as gifts from other doctors and relatives of deceased doctors who want a good home for items they didn't really want to keep. "Most of the collectors are doctors, but most doctors don't collect and consequently know very little about the origin of their instruments," Dr. Hambrecht said.

He belongs to the Medical Collectors Association in New York which has about 100 members. His hobby has stimulated a desire in other family members to collect antiques as well. His wife now collects teddy bears and antique strollers, while one of his sons, 13, collects antique beer signs. To each his own. □

SOME NOTES ON THE CLEANING AND PRESERVATION
OF ANTIQUE MEDICAL COLLECTIBLES

by F.Terry Hambrecht, M.D.

To many of the members of the Medical Collectors Association one of the most enjoyable experiences is to obtain a dirty, and yes, often smelly, old medically related item and to watch it jump to life as it is cleaned and restored to a likeness of its former self. In these notes I would like to share some of the cleaning and preserving techniques which I have personally found useful. I am not a professional restorer and must warn you to use these tips "at your own risk". Also they are by no means complete. I would hope that they serve as the start of a dialogue between members, and perhaps a small section in each newsletter could be devoted to such tips.

There are several antiquarian books which I have found useful and are available at many medical libraries. In A System of Operative Surgery (Lippincott, Grambo and Co, Philadelphia, 1852) Henry H Smith, M.D. discusses the preparation and sharpening of instruments as well as the preservation of instruments. This book also includes many excellent engravings of old surgical instruments. Instrument makers put out very detailed catalogs over the period 1872-1889 which included descriptions of operations and original articles by prominent surgeons of the day. Detailed descriptions of instrument materials and fabrication techniques were also given, especially in the 1889 edition of The American Armamentarium Chirurgicum by George Tiemann & Co. For example, under a section entitled Care of Instruments, Tiemann states that "handles may be made of ebony, ivory, hard rubber or shell. Ebony is more generally used for larger instruments. Ivory is more expensive, but makes a durable and beautiful handle- especially adapted for scalpels and eye instruments. Shell is more used for light instruments- as those of the pocket case. Hard rubber makes an excellent handle, combining neatness, lightness and durability, and may be baked on to the blades when desirable- as for antiseptic knives, etc." When discussing preservation of instruments Tiemann warns that this "requires careful attention to the following details: Select a place always free from moisture and dirt for their safe keeping. Polished instruments should be suspended or placed in cases lined with oil-dyed velvet. After being used every instrument should be thoroughly cleaned with warm water, and perfectly dried with chamois, or the fire, before it is returned to the case."

Perhaps the most useful modern book on this subject is Collecting and Restoring Scientific Instruments (R. Pearsall, Arno Publishing Co, New York, 1974). The chapter on cleaning and renovation of scientific instruments discusses brass, copper, lacquering, gilding, wood, veneers, aging metal and wood, and briefly mechanical repairs. There are two problems in using this book. First, it was written in Great Britain with the result that many of the brand names are not available worldwide. Also in the U.S.A., the Environmental Protection Agency and other groups interested in protecting our health or protecting themselves from lawsuits have made it rather difficult to get many of the chemicals needed. For example, some of Mr Pearsall's formulas require such ingredients as barium sulfide, nitric acid, gamboge and bichromate of potash.

Mr. John Slaten, a gentleman with over thirty years experience in surgical instrument repair, recently wrote a book entitled, Sharpening and Repair of Surgical Instruments ... A Practical Guide (Available from Slaten Publishing Co, 333 W. Dayton #326, Madison, WI 53703). Although this book focuses on modern stainless steel instruments, there are many tips on how to repair and sharpen instruments which are equally applicable to antique instruments.

There are different philosophies in the care of antique medical collectibles. My personal preference is to clean them of years of dirt and grime but not to remove the aged "patina". However some of the following techniques go beyond this stage and remove surface oxidation, sulfides, etc so it is best to test them first where they won't show to be sure you get the degree of cleaning that you want.

The metals used in antique instruments are principally steel, brass, copper, bronze, pewter, aluminum, silver, gold and occasionally platinum. Dirt, grease and old wax can be removed with petroleum distillates such as mineral spirits. A particularly effect solvent is Dupont's Prep-Sol (3919S) available at automobile paint distributors. After about the mid 19th century steel instruments were often nickel or chrome plated. Whether plated or not the principal problem is usually rust. Light rust originating in small pits can be removed by vigorous rubbing with an automobile wax such as Rain Dance which contains a fine pumice. This does not remove the plating unless it is flaking, and the wax leaves a protective layer which resists further rusting. Heavier rust can be removed by soaking in ordinary kitchen vinegar. This often takes several days, but with occasional brushing with an old toothbrush, it usually removes rust in deep crevices such as in hinges. A quicker way to remove rust is with phosphoric acid which is also available at automotive paint distributors. Use rubber gloves and don't use it if

you want to preserve any plating. It also slightly etches the metal so it is best to try it first where it won't show. Old instruments can be replated, but pick your plater carefully. The most important part is the metal preparation and polishing. I have had good luck with platers who specialize in plating of antique machines such as slot machines and poor luck with automotive and industrial platers. Check with your local home amusement dealer for names. If a steel instrument predates plating it can be polished with a cloth buffing wheel by applying white rouge (e.g. Sears, 9-2896) sparingly to the face of the revolving wheel, then lightly holding the piece against the wheel. Repeat applications as necessary. Again a final application of auto wax serves to protect the new surface.

Brass, copper and pewter can be cleaned and polished with Brasso which is available in most hardware stores. By carefully controlling the amount of rubbing, it is possible to clean the metal without imparting a bright shine. On the otherhand if an original mirror finish is desired this is also possible but be prepared to rub. Sometimes a preliminary cleaning with a buffing wheel and tripoli compound will reduce the amount of polishing with Brasso.

Aluminum started to appear around the start of the 20th century. It really can't be polished because of the protective dull white oxide that forms on its surface. It can be cleaned with a cloth wheel and tripoli compound or with 0000 grade steel wool. There are many silver polishes on the market and silver can also be buffed with a cloth wheel and red rouge.

A very irritating problem is the adhesive residue that remains from price stickers and old cellophane tape. Naphtha based solvents such as Ronsonal or Zippo lighter fluid will remove these gummy substances and are usually innocuous to finishes.

Ivory can be cleaned with a toothbrush and a toothpaste which contains a fine pumice such as Colgate. Ivory that has yellowed can be bleached in sunlight or if you want to speed things up you can use an abrasive cleaner that contains bleach such as Comet. Be sure to thoroughly wash the ivory with warm water after cleaning it to remove all of the cleaning compounds.

There are many preparations on the market to clean and protect wood. I have been pleased with Formby's furniture cleaner and Formby's lemon oil furniture treatment. Full instructions are on the containers. It is amazing how much dirt can become trapped in an old wood finish. Often the wood does not require refinishing, but rather just a good

cleaning and a protective coat of lemon oil. Old wood scientific instruments such as stethoscopes often used beeswax finishes. This can be reproduced by adding a small quantity of turpentine to beeswax in a pan and heating it until the wax unites with the turpentine. This polishing wax can then be applied directly to the wood surface.

Leather needs regular attention to protect it from drying out and from decay. A good preparation to clean old leather books, saddle bags, etc is Propert's Leather and Saddle Soap. Once the leather is well cleaned, a good leather preservative should be applied. These are available from library supply houses. Preservatives are important because once the leather has rotted there is nothing that will restore it.

In these notes I have tried to describe some of the techniques that have worked well for me and to give enough detail so you can reproduce them. I hope you will share your favorite receipes with us in future issues of the Newsletter.



THE MONTGOMERY COUNTY HISTORICAL SOCIETY INC.

THE STONESTREET MEDICAL MUSEUM of The Montgomery County Historical Society

The Stonestreet Medical Museum is in the original Rockville office building used by Dr. Edward Elisha Stonestreet from 1852 to 1903.

Set up to suggest a 19th century country doctor's office, the Museum contains displays of medical, surgical, dental, and apothecary instruments, equipment, and furniture of the period. The collection, which is constantly growing, contains such unusual items as a c. 1850 stethoscope, an 1897 phonendoscope, a Civil War army issue amputation kit, a dental key, phlebotomy instruments such as spring scarificator and lancets, Farnier and Bedford forceps, and ether drop bottles and ether masks. A small library of 19th century medical books is being developed.

Moved in 1972, the building is on the grounds of the 1815 Beall-Dawson House, headquarters of the Montgomery County Historical Society, 103 West Montgomery Avenue, Rockville, Maryland. The Museum is open to the public Tuesday through Saturday from 12 to 4 p.m. and the first Sunday of the month from 2 to 5 p.m. The admission of \$2.00 includes a tour of the Beall-Dawson House as well as the Stonestreet Medical Museum.

ALEX PECK, ANTIQUA SCIENTIFICA

Fine Quality
Artifacts from
the History of
Medicine and Science

P.O. BOX 710
CHARLESTON, IL
61920 USA
217/348-1009

TREPANNING: 1750-1880 PART I

In the span of time from about 1750 to 1880 a remarkable change took place in the design and use of surgical instruments. This article and others to follow will chronicle some of the aspects of this transition as seen in trepanning instrumentation. All examples discussed and photographed are from the inventory of the author.

Arguably one of the most interesting groups of pre-sterilization instruments is that of trepanning tools. Made to be used near the brain, trepanning instruments themselves seem to take-on a magical quality, which would have been an asset to both doctor and patient alike during an operation which offered small chance of success.

A most appealing sort of trepan is the yoke or gullwing-handled trepan illustrated in Figure 1. The turned and polished steel handle of this c. 1750 example reflects the exuberance of the Baroque and Rococo Europe in which it was made and used. Compare the lively undulating sweep of the gullwing pattern to the more measured and restrained form of the Fella's trephine of c. 1880 [Figure 2] and you are immediately aware that a dramatic restructuring of surgery, not to mention society, has taken place. One can certainly understand the theory behind the design of the aseptic Fella's trepan, but all is not gain. Gone is the mystical quality and the delight to the eye. Made to be sterilized, the late 19th century trepan is itself sterile and inanimate. Void of any sign of individual craftsmanship and beauty, it rather reflects the demands placed by the germ theory, a mystery uncovered. While this may make for good surgery, it marked the death knell of interesting and artful instrumentation.

Let us now turn to a closer look at the trepanning set found in Figure 1. The gullwing trepan was known at least by the 17th century, and John Woodall (1570-1643) included an example in his well-known book, **The Surgeon's Mate**, published in 1639 [Figure 4]. The kit in Figure 1 probably dates to c. 1750 as it contains the drill pin spanner key attributed to Samuel Sharp (1700-1778), which will be discussed later, and as the pattern of the brass handle atop the case is typical Chippendale.

The two drills in Figure 3 are signed **YOUNG**. Though Bennion records no maker by that name, I have had several small surgical instruments signed **YOUNG, EDINBURGH**. I propose that the makers are one and the same. Considering the circumstances by which I acquired the set and that the instruments are the type that would have been purchased in Edinburgh and brought to the American colonies by the many colonial surgeons who were trained in Edinburgh in the second half of the 18th century, I suspect that this set is a relic of the American Revolution (1775-1783).

The Young set contains a typical assortment of 18th century trepanning instruments. This includes the steel gullwing handle and its two interchangeable drills with crowns of differing diameters, a brush to clean the bone dust from the crowns, a double-ended elevator for lifting the bone disc cut by the drills and other fragmented bone, a pair of steel forceps also used to lift the bone disc from the cranium, a key for adjusting and removing the perforator pin from the center of the drill crowns, and two walnut-handled steel lenticulars which were used for scraping the cranium prior to drilling, shaping and trimming the hole cut by the crown, and for tamping the brain. The Young set would have also had an arrowhead perforator drill which is now lost.

Before discussing some of the functions of the individual instruments in the Young set, let me insert a brief description of the typical trepanning operation itself. A good summary of the basic procedure is presented in Stephen Smith's **Hand-Book of Surgical Operations**, p. 239, which was published in the early 1860s and much used by the Union surgeons of the American Civil War (1861-1865).

Operation.--The patient being placed in the recumbent position, with the head slightly raised, an incision is made down to the bone, having the form of a V, T, or +, or it may form a semicircle; the bone being scraped, the operator seizes the handle of the trephine with his right hand, and fixing the perforator by its screw, so that it protrudes slightly beyond the teeth, he places the perforator in the center of the bone to be removed; the instrument is now worked alternately backwards and forwards, until the teeth have cut a groove sufficiently deep to receive them; the perforator is then loosened and slid up in the shaft and fixed, to avoid wounding the membranes; great care should be taken to maintain the instrument in a position perpendicular to the part operated upon, in order to avoid its penetrating more deeply on one side than the other, and thus suddenly and unawares wounding the cerebral membranes. It is important to examine the depth of the groove frequently with a toothpick, to ascertain how nearly the instrument has completed the section of the bone; the teeth of the trephine may occasionally require cleaning with a small brush or wet sponge. The disc of bone should be raised with the elevator and the edges smoothed with the lenticular knife at the other end of the elevator.

With Smith's description as background (N.B., fixing the perforator and the combination elevator/rasper differ from the operation of the Young instruments), several aspects of the use of the Young trepanning set may be further studied.

Once having coupled the correct size drill crown to the gullwing handle, the surgeon had to fix the perforator pin. The pin in the Young set follows the Sharp's pattern and the end away from the point is made as a threaded screw which will screw into a female tap at the rear center of the hollow crown saw. The pin has four sides and resembles a pyramid when viewed at the point. In fact, the pin was called a "pyramid" in the 16th and 17th centuries (Lowe, p. 319). The pin was screwed into the crown by slipping over its pointed-end a four-sided slotted-key which would grasp the pin and provide the necessary hold to apply a turning motion. Figure 5 illustrates the pin fitted to the key and in position to be screwed into the crown. In the next figure the pin has been removed from both the key and the crown. Note also the bone disc which bears the scoring of the pin at its center.

After the cranium had been carefully cut to the proper depth by the drill and crown, as Smith remarks, the bone disc had to be and removed by an elevator. The most commonly seen elevator is a lever with both ends grooved for better traction and each end slightly curved to accommodate various angles of leverage (see Figure 3, far right). A second pair of levers are in the Young set, though at first they may not be readily apparent to the uninitiated. Here I refer to the trepan handle itself. Each of the tips of the gullwing are also grooved and curved. A comparison of the 'regular' elevator and that formed by the gullwing is shown in Figure 7.

Elevator forceps are common to trepanning sets exemplified by the Young set. Figure 8 illustrates such a pair and demonstrates the forceps' jaws grasping a bone disc. Elevator forceps are generally not found in trepanning sets made after 1780. I suspect they were not as practical as they first appeared to be and that they never gained widespread acceptance.

Since the drills could not be used to a depth to insure a full circle cut of the cranium for fear of damaging the brain, the final freeing of the bone disc depended upon a break forced by the elevators. This left the opportunity for sharp splinters to be made and left about the round cut in the cranium itself. The negative of such a splinter can be seen as a small 'ear' on the bone disc pictured in Figures 6 and 7. As a possible source of irritation to the 'cerebral membrane,' splinters could not be left about the opening next to the brain. Lenticulars were employed, in part, to cut and file away the bothersome splinters. With 'padded' faces to prevent damage to the brain itself, lenticulars have knife sharp edges for cutting and rasping.

Having hit the major aspects of the Young trepanning set, I will stop my comments here. A future article will examine closely a very fine large trepanning kit I have which is Napoleonic and marks the high-water mark of trepanning instrumentation.

REFERENCES

Elizabeth Bennion, **Antique Medical Instruments**, London 1979.

Peter Lowe, **A Discourse of the Whole Art of Surgery**, London 1654.

Jeremy Norman, **Medicine and the Life Sciences**, Catalogue Fourteen, San Francisco 1984. Figure 4 in this article reproduced by Mr. Norman's permission.

Sharp and Smith, **Catalogue of Medical Instruments**, Chicago c. 1900.

Stephen Smith, **Hand-Book of Surgical Operations**, New York 1863.

SHARP & SMITH, CHICAGO.

TREPHINES AND DRILLS.

SHARP & SMITH

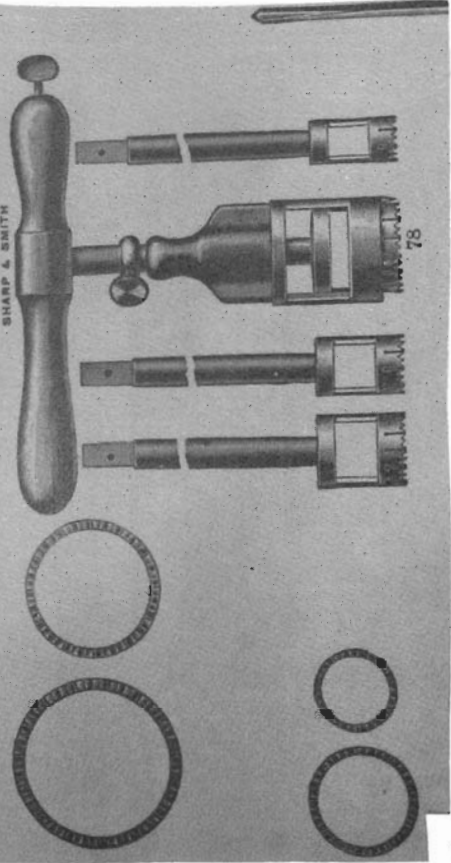

2

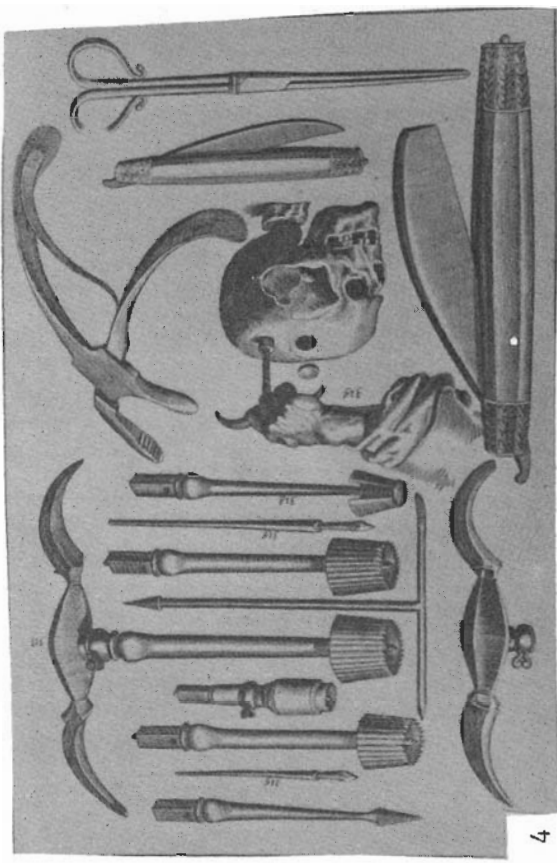

4



1

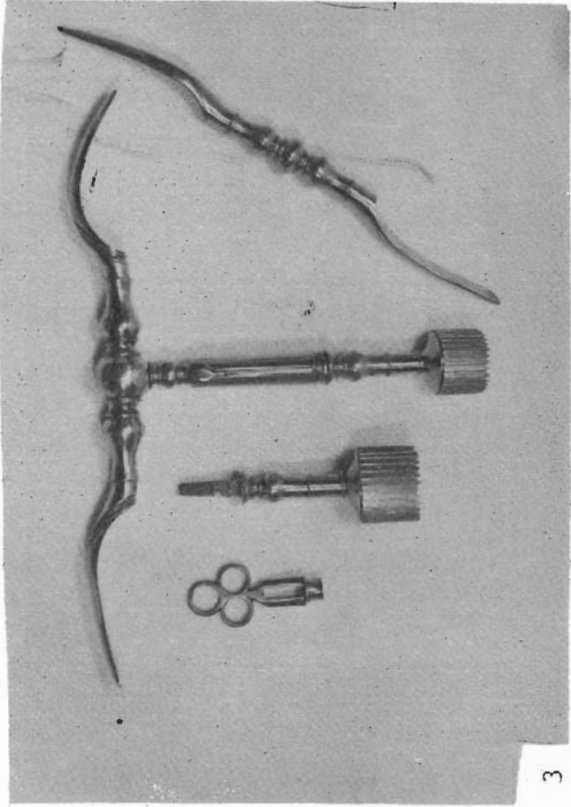

3

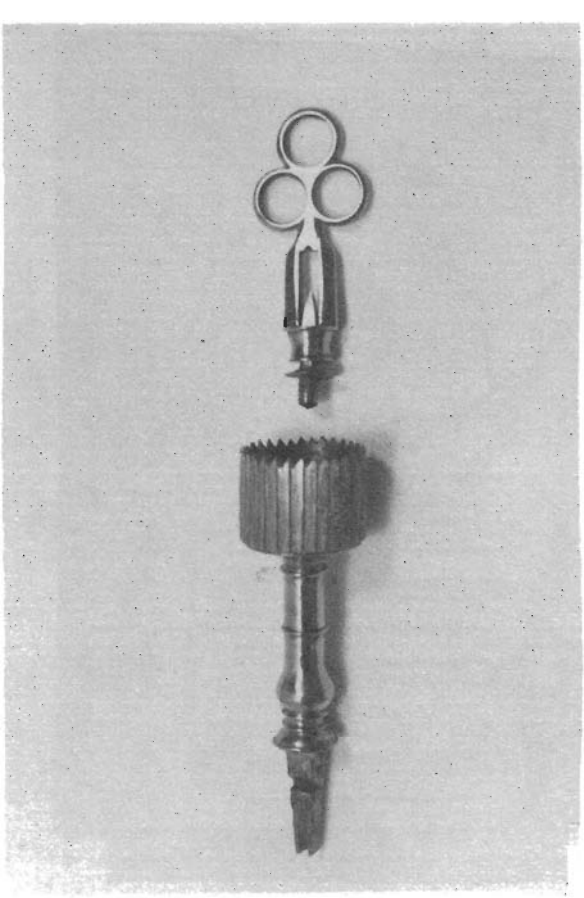

6

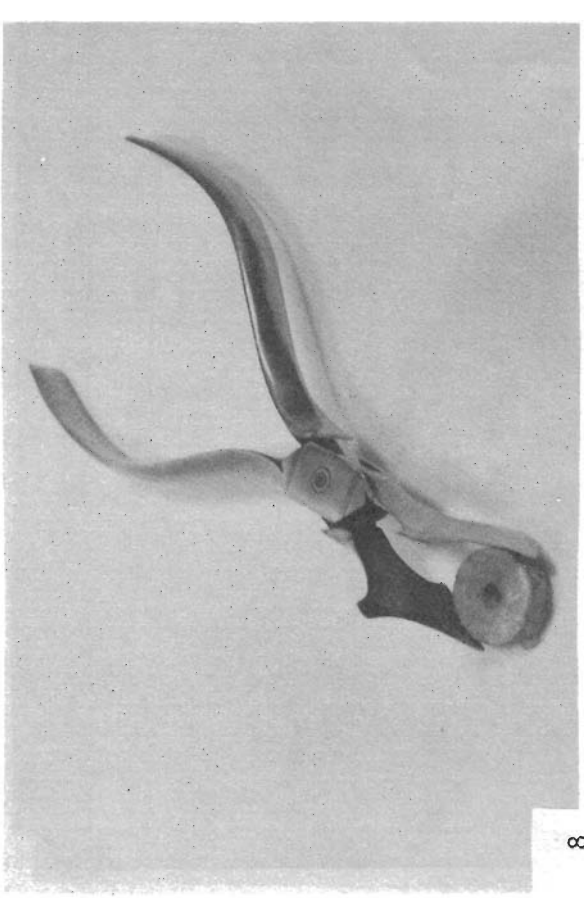

8

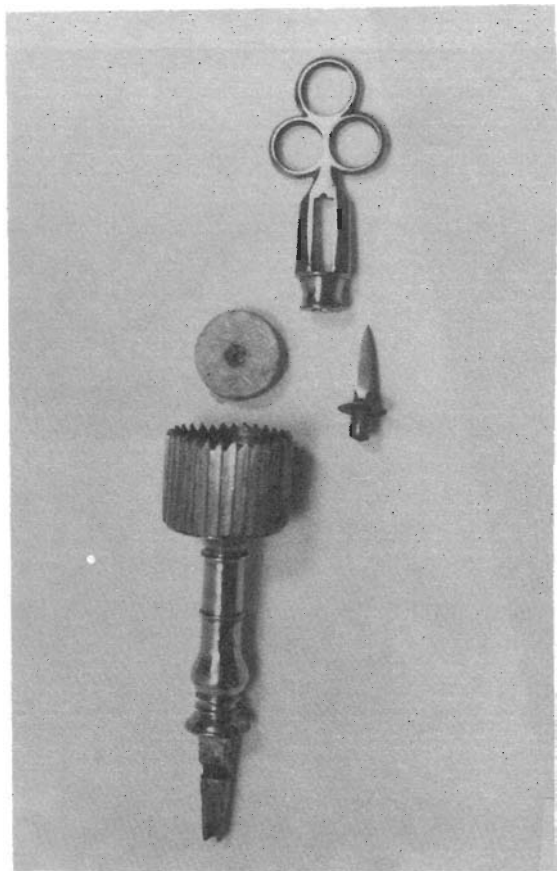

5



7

MEDICAL MUSEUMS OF THE WORLD

PART VI

ITALY

BY

PROFESSOR E. T. PENGELLEY

ITALY

It was in Italy that the Renaissance, or the revival of learning, began and it was not long after this before some of their best thinkers turned their attention to natural phenomena. Great centres of scientific learning grew up, particularly in Florence, Bologna, Pisa, Venice, Padua, and later at Naples. By far the most famous and prominent Italian scientist has been Galileo Galilei (1564-1642). Although biology and medicine were not primarily his field of endeavour, his influence on all science was so great that I will have more to say about him. In the fields of biology and medicine, other Italians have played major roles. These include the Roman, Claudius Galen (130-201), Marcello Malpighi (1626-1694), Francesco Redi (1626-1697), Lazzaro Spallanzani (1729-1799) and others. Unfortunately nothing survives of their associations of which we are aware, and many of their important ideas have been superseded. Therefore I will devote this section on Italy to some of the traditionally great centres of scientific learning. It will also include an account of the great anatomist, Andreas Vesalius (1514-1564), who although not an Italian, taught and did his major work at Padua.

With Italy's long and distinguished cultural history, going back to the Roman civilization and beyond, there is much more to see than just places of scientific interest, though often the latter are interwoven with the former. Italy has excellent roads in general, and their Autostrada criss-cross the country making it easy to travel relatively long distances in a short period of time. There are also many rail and bus services as well. Rome, on the river Tiber, is the capital, and it will be convenient for me to take this as a central point of orientation, though there are also many convenient routes into northern Italy from France, Switzerland and Austria. I feel compelled to warn visitors to Italy that the opening hours of their institutions are very variable, and in addition there is no guarantee that they will be open even during the stated times!

FLORENCE

Location - 315 kilometers northwest of Rome.

Train - From Rome direct.

Road - Take the A1 Autostrada north from Rome, and then one of the many exits to Florence.

Florence, situated astride the Arno River, was an old Roman colony, and a military camp which Julius Ceasar built in 59 B.C. It became of some importance under the Carolingian Emperors, but it was in the 15th and 16th centuries, when under the rule of the Medici family, that it rose to supreme cultural heights. In large measure this has been maintained ever since. During World War II, allied soldiers approaching the city were told that "The whole city must rank as a work of art of the first importance." This accurately describes Florence, but it did not prevent terrible destruction. Some of Florence has gone forever, but today much restoration has taken place, and it is a very lovely place to visit. I cannot recommend too strongly a good historical guide book.

Before describing actual places of biological and medical interest in Florence, it will be well to give a short historical account of medicine in the university. It is of great interest, and has something to teach us all.

During the Middle Ages, and starting about the 10th century, there was a school of medicine at Salerno, but no doctorate degree was given. Next in Italy came Bologna, first with law (1150) and then medicine. Art and music were also taught, but only law could receive a high degree. It was said that this was quite natural, because only law could be discussed, whereas medicine could not (i.e., the facts were known!). The man who eventually came to the defense of medicine was a Florentine, Taddeo Alderotti. He argued the case in Bologna, won the day, and about 1285 it became possible to award a high degree in medicine. This in fact may be considered the origin of medical degrees as we know them today. Padua started as a university in 1222, with a faculty of medicine. This was followed 22 years later by the founding of the University of Naples by Frederick II.

The University of Florence was founded in 1321 and at its inception there was a medical school. Unfortunately neither the university nor the medical school functioned very well mainly because its founders were merchants, who bargained for the professors and always thought they were paid too much--times have scarcely changed! Later the students ran the university, and in many cases hired the professors.

In the middle of the 16th century, Cosimo de Medici turned all the students out of Florence and sent them to Pisa. Florence was of course his capital, and like many a ruler, before and since, he viewed students as a threat. However, the Hospital of Santa Maria Nuova, founded at the end of the 13th century remained, including its school of surgery. The system evolved whereby the students took 4 years of theory at Pisa, and then went to the hospital in Florence for two years of clinical work, at the end of which they received a masters degree in surgery.

In the 17th century some pupils of Galileo's founded what was primarily a scientific academy at the Court of the Medici. It was called the Acedemia del Cimento, and they met occasionally in the Petti Palace. Lorenzo Bellini, Giovanni A. Borelli, Francesco Redi and Marcello Malpighi were all members of this academy, and exerted a major role in the advancement of science.

In the middle of the 18th century, the school of medicine at Florence was reformed by a professor of anatomy, Antonio Cocchi, and at the end of the century was again reorganized by the Grand Duke Pietro Leopoldo of Austria. The school was now "avant-gard", for it had courses in pediatrics, dermatology, psychiatry and the history of medicine. There was also a pediatrics hospital, which dated from 1420 as a home for foundlings.

In 1840 disaster struck the still surviving school of surgery, in the form of another tyrannical ruler, Leopold II, who closed it and ordered the students to do everything at Pisa. It was not until 1859, after the war of independence, that a private school of medicine returned to Florence and was finally recognized by the state in 1923.

Instituto e Museo Storia della Scienza
 Piazza dei Giudici 1
 Florence

Opening hours: Daily 10.00-13.00 and 14.00-16.00. There is a small charge for admission. Guide books and other literature are available, some in English. Some of the guides speak a little English and French as well as Italian.

This is an Institute and Museum of the History of Science, and is certainly one of the best in the world. It is situated near the Palazzo Castellani, on the banks of the Arno near the Ponte Vecchio, and adjoins the Uffizi Gallery. The displays in the museum are remarkably comprehensive and include biology and medicine, though they are heavily weighted in the history of physics and the work of Galileo (see under Pisa).

On the ground floor, where one enters, is an apothecary and chemistry (old chemistry) museum, also a collection of old clocks, including a pendulum clock attributed to Galileo. However, the main collections are on the first floor (second floor to us). These are displayed in 9 rooms as follows:

1. Mathematical instruments.
2. Mathematical and navigating instruments.
3. Geography and sundials.
4. Cosmography and geography.
5. The Galileo room, including lenses, telescopes and thermometers associated with him, and some of his written works in original editions.
6. Telescopes of the 17th and 18th centuries, and microscopes of the 17th century.
7. Microscopes from the 18th century to the present.
8. Telescopes of the 18th and 19th centuries.
9. Various mechanical instruments.

Also in the hallways are portraits of many famous scientists.

On the second floor (third floor to us) there are 10 rooms with the following displays:

- 1, 2 and 3. These rooms are really a library of old and rare scientific books, ranging back to the 14th century. One cannot help but stand in awe as one looks at this superb and priceless collection.
4. Mostly the history of cartography, but also displays where instruments are matched to drawings in old books.

5. Lenses, including an incendiary lens of the 17th century, which both Sir Humphrey Davey and Michael Faraday came to Florence to see, in connection with their studies of the nature of fire.
6. Pneumatic instruments.
7. Electrostatic instruments.
8. Anatomy models.
9. Medical instruments and biological wax models.
10. Medical instruments.

This museum is under the direction of Professor Maria Luisa Righini Bonelli, and I cannot speak too highly of her expertise and achievements. I must note also that the museum carries on active research in the history of science, and tries constantly to expand its displays. Finally, I would warn the visitor to plan to spend some time here, as there is a great deal to see.

La Chiesa di Santa Croce
Piazza Santa Croce
Florence

Opening hours: Variable - enquire locally. This is a church.

When Galileo died in 1642 he was buried in the churchyard of Santa Croce. However, 100 years later when the wrath of the church had somewhat died down, his body was transferred inside the church with a suitable monument, and this can be seen today.

Ospedale di Santa Maria Nuova
Piazza Santa Maria Nuova
Florence

Opening hours: Normal business hours. This is a working hospital.

This hospital was founded at the end of the 13th century, and interestingly enough the founder was Folco Portinari, the father of Beatrice, Dante's inspiration. It is one of the oldest in the world, and played a major role in the development of early surgery.

Ospedale di Pediatria
Piazza S. S. Annunziata
Florence

Opening hours: Normal business hours. This is a working hospital.

This was originally a home for foundlings, and dates from 1420. The architect was Filippo Brunelleschi (1379-1446), and the building also has some magni-

ificent sculpture by Luca della Robbia (1400-1482). At the side of the main entrance there is a bell placed low down, so that it could be rung by children seeking help. It is a very beautiful and interesting place, and one of the earliest pediatric hospitals in the world.

**Biblioteca della Facoltà di Medicina
Policlinico di Careggi
Viale Morgagni
Florence**

Opening hours: Normal business hours.

This is a magnificent medical library, particularly rich in early medicine in Italy. It can only be used by special permission of the librarian, but visitors can ask to see it, and the librarians are very helpful.

**Museo Zoologica La Specola
17 Via Romana
Florence**

Opening hours: Monday, Tuesday and Wednesday, 9.00-12.30. Saturday, 14.00-17.00. Sunday, 9.00-12.00. Closed Thursday and Friday.

This museum has as its main display a very fine collection of biological wax models.

The visitor to Florence will of course want to see many more things than I have mentioned here, but in closing I would just like to suggest that you do not miss the Villa i Tatti, Via di Vincigliata. This contains the art collection and art history library of Bernard Berenson, left by him to Harvard University. It is a bit "out of the way", but more than worth the effort to get there. It is open Monday - Friday only, 9.00-13.00 and 14.30-18.00. Closed for the month of August.

NAPLES

Location: 220 kilometers southeast of Rome.

Train: From Rome direct.

Road: Take the A2 Autostrada south from Rome and then one of the many exits to Naples.

The history of Naples goes back to at least 500BC when it was a Greek colony named Parthenope, and since then has played an increasing part in Italian history. It is the third largest city in Italy with a population of over one million, a huge port, and set in beautiful surroundings with a sub-tropical climate.

Stazione Zoologica di Napoli
 Villa Comunale
 80121 Napoli
 Naples

The Villa Comunale is a park (in the centre of which is the Stazione Zoologica) which borders the Via Caracciolo along the seafront.

Opening hours: Normal business hours. This is an active working institution, but by application to the main office permission to see over it is usually granted.

The Stazione Zoologica (Marine Biological Station) at Naples has played an enormous part in the development of all modern biology, and no one interested in the history of biology and medicine will want to miss it, not only for its historical significance, but also for its massive and imposing architecture all set in a beautiful park - regrettably often vandalized.

This Marine Biological Station is by far the oldest in the world and set the pattern for the future. It was founded in 1872 by the young German doctor, Felix Anton Dohrn (1840-1909), who had studied both medicine and zoology at a variety of universities, but devoted his efforts to zoology. Anton Dohrn was "blessed" with a very rich father, Carl August Dohrn, who liked to support scientific research, and gave large sums of money to establish the station. There were also many other founding donors, including Charles Darwin. It was not exactly an accident that the foundation stone was laid in 1872, for that was the year that the famous Challenger Deep Sea Exploring Expedition set out, and as a result of the Darwinian theory of evolution by natural selection (1859), many scientists were devoting their efforts to marine life in attempts to trace its evolutionary origins. At that time many were convinced that "ontogeny recapitulates phylogeny", i.e. that the embryological development of an individual animal recapitulates its evolutionary development. Thus it was thought that to explain evolutionary development, all that was necessary was to study embryological development. Unfortunately it did not prove that simple, but this was one of the main problems that early marine zoologists worked on at the station, and they soon found the many difficulties.

From the beginning the station's main function was marine biological research, and still is. Anton Dohrn also insisted that it should be highly internationally orientated, and that scientists from all over the world should come there to work and exchange ideas. A truly far sighted and very productive concept which has advanced natural biological knowledge enormously. To give an idea of the scientific importance of this first marine station, it is only necessary to note that over 20 Nobel Laureates have worked there at one time or another.--I mention simply a few: Jacobus Van't Hoff, Ilja Metschnikoff, Otto Warburg, Thomas Hunt Morgan, Otto Loewi, Albert von Szent-Gyorgyi, James Watson, Maurice Wilkins, George Wald and Karl von Frisch.

For most of its life (now well over 100 years) the station was in private hands, but after World War II financial problems became so great that it was nearly forced to close. However, it is now under the direction of the Italian Ministry of Education, and it is hoped that better times are ahead.

Apart from the whole setting and structure of the station, there are two special things that the visitor should not miss. The first is the Marine Aquarium (one of the first in the world), which is currently (1984) undergoing extensive renovations.--The second is the library, which apart from its up to date research holdings, it is one of the best historical biological libraries in the world. The Archivist is Senora (Frau) Christiane Groeben, who is very knowledgeable and delighted to show visitors everything. In addition to her native German, she is fluent in Italian, French and English! She is also an excellent historian of biology.

The Stazione Zoologica di Napoli has a distinguished place in the history of biology and is well worth a visit by those so orientated.

PISA

Location: 300 kilometers northwest of Rome.

Train: From Rome direct.

Road: Take the A16 Autostrada to the north and exit at Pisa. It may also be reached from Florence via the A11 Autostrada.

Almost everyone knows that Pisa is the home of the "Leaning Tower", but what is of far greater importance is that it was also the home of Galileo Galilei, one of the most influential scientists of all time.

Pisa on the Arno was originally a Greek colony, and is one of the many ancient towns in Italy, which through the centuries has suffered severely from the devastation of war (most recently World War II). As the same time, Pisa has managed to maintain a flourishing culture, and is a fascinating place to visit. It is regrettable that Galileo's birth place in Pisa is unknown, or perhaps does not survive, but fortunately there are still some direct associations with him.

Università di Pisa
Via XXIX Maggio 15
Pisa

Opening hours: Normal business hours. This is Galileo's university.

Galileo Galilei

Galileo will forever be remembered as the person, who more than any other, challenged and eventually overthrew a way of thought based on speculation and dogma, which was the hallmark of the all powerful ecclesiastical authorities. For this he substituted the experimental method, and deductions therefrom, which has become the major means of all scientific research. As a result he narrowly escaped with his life! But Galileo did much more than that.

He was born in 1564, the first child of a middle class family. Much of his early education was private, and at 14 he entered a monastery as a novice, intending to become a priest. However, 3 years later in 1581 he left the

monastery and entered the University of Pisa as a medical student. It seems he was not very interested in medicine but studied a great deal of mathematics, and left in 1585 without a degree. Four years later he was offered the chair of mathematics at Pisa and in 1592 went to the University of Padua (see elsewhere) where he found a much freer atmosphere for his work, which prospered. His time in Padua lasted 18 years, but in 1610 he went to Florence as a private mathematician to the Grand Duke of Tuscany. Most historians of the period agree that this turned out to be a disastrous move for Galileo, as Florence at that time was a rigid society, dominated by the Church, and it is not surprising that in the end Galileo was one of its victims.

Over his relatively long life span, Galileo's work and discoveries were vast, and I can only summarize them here. They included the discovery of the isochronism of pendulum oscillations, the equality of the velocities of falling bodies, the making of early thermometers and the refracting telescope, the latter making possible his astronomical observations and theories. He also very effectively applied mathematics to time and motion with undreamed of results. But, it was in 1632 that his greatest work was published. This was entitled "Dialogo sopra i Due massimi Sistemi del Mondo, Tolemaico e Copernicano" (Dialogue on the Two Chief Systems of the World, Ptolomaic and Copernican). Basically this book argued back and forth between the accepted Ptolomaic theory that the earth was the centre of the universe and the heavenly bodies revolved around it, and the Copernican theory where the sun was central, and the earth was a planet revolving around the latter. Galileo's telescopic observations and his calculations had of course convinced him that the Copernican theory was the reality. The year after "The Dialogue" was published he was brought before the Inquisition in Rome and forced to renounce his ideas. He also was to remain "under observation" for the rest of his life, which however was still spent under the patronage of the Grand Duke of Tuscany. He died in Florence in 1642.

The main building of the University of Pisa is located on Via XXIX Maggio between the Piazza Garibaldi and the Piazza Dante. The University of Pisa is one of the oldest in the world, with origins going back to the 12th century, but its chief claim to fame is that here towards the end of the 16th century, Galileo was successively both student and professor. The facade of the building is of recent construction, but the internal courtyard and balcony, which are of superb architecture, were built in the 15th century. It is really a thrilling experience to see this, and realize that Galileo himself walked this same courtyard. The library, located off the courtyard, is very rich in old scientific books, and contains some original documents of Galileo. The library is not open to the public, but visitors may make their requests known to the librarian, who in my experience was cooperative.

La Catterdrale
Piazza del Duomo
Pisa

Opening hours: Variable - enquire locally. This is a church.

The Cathedral of Pisa is of 11th century origin, and contains many magnificent works of art. However, from our point of view it contains the so called

"Lamp of Galileo". This is a great bronze chandelier strung from the ceiling of the cathedral. According to tradition it was while in church one day that Galileo observed the oscillation of the chandelier and subsequently established the isochronism of the oscillations of a pendulum. The tradition is quite possibly true, but in any case pleasant!

There are many other interesting things in the Piazza del Duomo, including the Leaning Tower.

PADUA

Location: 525 kilometers north and slightly west of Rome. 30 kilometers west of Venice.

Train: From Rome via Florence.

Road: Take the A1 Autostrada north from Rome, and follow this around Florence to Bologna. At Bologna join the A13, which skirts Ferrara and leads straight to Padua.

Padua is on the eastern side of the Valley of the Po in northern Italy. It claims its origin from Troy, but in any case it was certainly an important town in Roman times. In 1337 it came under the rule of the Carrara family, and was subsequently taken by Venice in 1405. This had some influence on the cultural life of the city, because Venice was not dominated by the church in Rome, and Padua was able to establish centres of learning which were relatively free of religious dogma. Padua was taken by the French in 1797, and was ceded to Austria in 1814. It finally came under the rule of the modern Italian state in 1866. It has been sacked, destroyed and rebuilt many times over the centuries, but fortunately escaped major damage during World War II.

Università degli Studi di Padova
Via Roma e Via 8 Febbraio
Padua

Opening hours: Normal business hours, but the "Palazzo del Bo" (see below) is open daily 10.00-12.00 and 14.00-16.00. This may be visited by guided tour (in Italian) only, and lasts about one hour. There is a small charge for admission, and literature (some in English) is available.

This is the central location of the University of Padua, and the main building here is universally called "Palazzo del Bo" (i.e., Ox Palace) or just plain "Bo". The university is one of the oldest in the world, with origins going back to the 13th century. What is so important to us is that Galileo taught here, and during the 16th and 17th centuries it was the leading university of the world; this was particularly the case for its school of medicine. It is a truism that there can be no physiology without anatomy first, and it was during the 16th century in the medical school at Padua that human anatomy was put on a modern footing. In fact, the University of Padua can rightly claim to be the founding point of modern medicine. The person principally responsible for this was Andreas Vesalius.

Andreas Vesalius (1514-1564)

Vesalius was of Flemish origin and born in Brussels in 1514. His family was poor, but he managed to enter the arts course at the University of Louvain, and in 1533 he went to the University of Paris to study medicine. At that time Paris was one of the leading medical schools, but like all medical schools of the day it was completely dominated by the "Galenic tradition", and to understand the revolution in anatomy brought about by Vesalius, it is necessary to understand what was meant by this tradition.

Claudius Galen (130-200) was the foremost medical doctor of ancient Rome, and became the private physician to the Emperor Marcus Aurelius. For his day, he was skilled in all branches of medicine and wrote over 80 treatises on the subject. None of these survive in the original, but only as copies. Until about the beginning of the 16th century they comprised the standard and accepted views on medicine, particularly the works on anatomy. This was unfortunate, because in Galen's day he was forbidden to dissect the human body and what his anatomical works consisted of was the anatomy of the barbary ape. For about 1000 years the anatomy of the barbary ape and human anatomy were considered one and the same!

As a student Vesalius was taught Galenic anatomy. In 1536 he left Paris and returned to Louvain, where he was able to introduce human anatomical dissection into the medical curriculum. In 1537 he went to the University of Padua, still as a medical student, but so great was his knowledge that he was granted a doctor of medicine degree the same year, and the day after this was made an instructor in anatomy and surgery. He immediately introduced anatomical dissection into the curriculum. Even more importantly he did the dissection himself, rather than assign this important task to an assistant. Even though the number of human cadavers was very limited, he quickly learned that there were many differences between the anatomy of Galen and the realities of human anatomy, and he gave public lectures to demonstrate this. Very soon however, he was at work on what was to become a turning point in medical education, and by 1543 this manuscript was ready for publication.

Vesalius' great work was entitled "De Humani Corporis Fabrica" (The Structure of the Human Body). It was printed and published in Basle, Switzerland in 1543. It is really a magnificent folio volume, and so accurate was it that it has often been said that medical students of today could learn their anatomy from this source without serious error. It is particularly notable for the standards of its illustrations. Traditionally these were said to have been done by the artist Jan Stephan van Calcar (c 1499-1550), who like Vesalius was Flemish, but this is not certain. However, there seems no doubt that they were done by students of the great Venetian artist Titian (1477-1576), and Calcar was one such student.

In retrospect it seems rather a pity that with the publication of "De Fabrica" Vesalius' academic career was over. The same year it was published, he left the university and entered the service of the Emperor Charles V. Later still he became physician to Philip II of Spain, and spent the last years of his life in Spain. In 1564 he went on a trip to the Holy Land, and on the return journey his ship was forced ashore on a small island. Vesalius died there shortly afterwards. His grave is unknown. Nothing can erase his great achieve-

ment, and with the publication of "De Fabrica" the premier place of the University of Padua in medicine was even more firmly established than ever.

Students of medicine came from all over the world, one of those being William Harvey (see under Folkestone, Britain).

Palazzo del Bo

At street level the Palazzo del Bo consists of a modern courtyard, built in this century, and it has fascist motifs on the walls. There are also plaques in memory of the university's war dead, all of whom "died for country and freedom"--it's the same the world over! Within is an inner courtyard, dating from the 13th century, and there is an interesting ritual carried out here every time a professor dies. His coffin is placed in the centre of the courtyard, and is then ceremoniously lifted three times by the students in tribute to the professor.

Upon entering the building the first anteroom is called the hall of Rectors. The walls are covered with frescoes by famous artists, a beautiful bust of Galileo who was a professor here for 18 years, and one of Copernicus (1473-1543) who studied medicine here from 1501-1503. Next is the impressive Great Hall (Aula Magna). It has been rebuilt many times, and the present one dates from the 19th century. On the walls are the coats of arms of the families of Rectors before the 16th century. In this century the custom was abolished. On the wall behind the main podium is the university's motto "Universa Universis Patavina Libertas" (Freedom to teach to everybody in Padua). The founders of the University of Padua were a group that broke away from the University of Bologna, where there was not freedom to teach. Despite this Padua, like so many other universities, has not always been able to live up to its motto.

After the Great Hall comes the Room of Forty. This is so called because on the walls are frescoes depicting 40 of Padua's famous foreign students. They include Nicolaus Copernicus (1473-1543), William Harvey (1578-1657), Sir Frances Walsingham (1530-1590), Oliver Goldsmith (1728-1774), etc. Also in this room is the original lecture podium, from which Galileo taught between 1592-1610.

Next is the Room of Medicine, and it is the original room built by the architect Morone in the 13th century. This is the main meeting room of the faculty of medicine, and the place where the medical students receive their degrees. A very fascinating tradition is preserved here. During the inquisition in the 16th century, it was very difficult to obtain human bodies for dissection, but it was permitted to will one's body for this purpose. In consequence of this it became the custom for the professors of anatomy to leave their own bodies to the medical school. In honor of those who did, their skulls were preserved and to this day occupy a prominent place in the Room of Medicine!

After the Room of Medicine comes the world famous Anatomy Theatre. It was built in 1594 by Fabrizio D'Acquapendente, and is by far the oldest in the world. It was also the first of its type, and proved to be the prototype of all later anatomy theatres. The great anatomist, Giovanni Battista Morgagni (1682-1771), taught here for over 50 years. To me this theatre is a true "gem" in the history of medicine. One cannot help being impressed by its small size,

the lovely clear lines of its architecture and the beautiful wood carving. Despite its small size there are standing places for 300 students. The circumstances surrounding its origin are very interesting. As explained previously, cadavers were hard to come by in the 16th century because of the inquisition, which forbade their dissection. Thus the Anatomy Theatre was deliberately built over a small canal. Dissections were always done at night, in order to be as inconspicuous as possible, and in addition the cadaver was floated on a barge down the canal under the theatre and simply lifted from the barge right onto the dissecting table. The opposite could and did take place, for when the professor got word that the papal police were on their way, the body was swiftly handed down onto the barge again and floated away. Such were the perils of anatomy in the 15th century! The visitor is allowed to walk in the theatre, and one can lie on the dissecting table to get a "cadaver eyed view" of the scene! The theatre was used until 1772, but since then has essentially been a museum piece. During World War II, it was taken apart and stored in a safe place. When it was reassembled after the war it was placed on a site slightly removed from the original.

There are several other historical rooms in Bo, but it is not necessary to describe them further. Of great interest, however, is a cafe just across the street from the main entrance of Bo. This is the famous Caffè Pedrocchi, which dates from 1831. It is of striking architecture and has played a large part in the life of medical students at Bo, the latter always having been highly elite and male orientated. Since the inception of the Caffè, there has been an interesting custom carried out each year by the graduating class of medical students. Upon leaving the Room of Medicine, where their degrees are awarded, they ceremoniously march across the road to the Caffè Pedrocchi, where they proceed to drink heavily, and each student in turn has to stand up on his chair and boast about his sexual exploits during his years as a student. It is said that some fantastic stories have been told here! Before leaving Bo, the visitor should walk over to the Piazza dei Signori and see the huge pre-Copernican Astronomical Clock, with the earth at its centre, and the sun revolving around it.

Biblioteca Pinali
(Stori della Medicina)
Università Institute di Anatomica
Via Gabriele Falloppio 50
Padua

Note: This is on the second floor of the Anatomical Institute at Via Gabriele Falloppio 50, but the street is gradually being renumbered and the Institute will become 16.

This is the old medical library of the university, with priceless collections of very ancient medical books--all beautifully maintained. Regrettably, the library is closed for lack of funds. However, by making special application to the Director of the Anatomical Institute, visitors are usually granted permission to see it. It is worth the effort.

Before leaving Padua, I can only hope the visitor will also take the opportunity of seeing its wealth of art, architecture and sculpture. Also the

Giardino Botanico at Via Orto Botanica 15. It is the oldest botanical garden in Europe, dating from 1545, and is still very active.